

WT  
**SECTION**  
**ROAD WHEELS & TIRES**

A  
B  
C  
D

WT

**CONTENTS**

<b>PRECAUTION</b> .....	<b>WIRING DIAGRAM</b> .....	F
<b>PRECAUTIONS</b> .....	<b>TIRE PRESSURE MONITORING SYSTEM</b> .....	G
Precaution for Supplemental Restraint System (SRS) "AIR BAG" and "SEAT BELT PRE-TENSIONER" .....	Wiring Diagram .....	
Precautions Necessary for Steering Wheel Rotation After Battery Disconnection .....	<b>BASIC INSPECTION</b> .....	H
Service Notice or Precautions .....	<b>DIAGNOSIS AND REPAIR WORK FLOW</b> .....	I
<b>PREPARATION</b> .....	Work Flow .....	
<b>PREPARATION</b> .....	<b>ADDITIONAL SERVICE WHEN REPLACING BCM</b> .....	J
Special Service Tool .....	Description .....	
Commercial Service Tool .....	Work Procedure .....	K
<b>SYSTEM DESCRIPTION</b> .....	<b>TRANSMITTER WAKE UP OPERATION</b> .....	L
<b>COMPONENT PARTS</b> .....	Description .....	
Component Parts Location .....	Work Procedure .....	M
Component Description .....	<b>ID REGISTRATION</b> .....	N
BCM .....	Description .....	
Transmitter .....	Work Procedure .....	O
Tire Pressure Receiver .....	<b>DTC/CIRCUIT DIAGNOSIS</b> .....	P
Information Display .....	<b>C1704, C1705, C1706, C1707 LOW TIRE PRESSURE</b> .....	
<b>SYSTEM</b> .....	Description .....	
System Description .....	DTC Logic .....	
<b>DIAGNOSIS SYSTEM (BCM)</b> .....	Diagnosis Procedure .....	
<b>COMMON ITEM</b> .....	<b>C1708, C1709, C1710, C1711 TRANSMITTER</b> .....	
COMMON ITEM : CONSULT-III Function (BCM - COMMON ITEM) .....	DTC Logic .....	
<b>AIR PRESSURE MONITOR</b> .....	Diagnosis Procedure .....	
AIR PRESSURE MONITOR : CONSULT-III Function (BCM - AIR PRESSURE MONITOR) .....	<b>C1716, C1717, C1718, C1719 TRANSMITTER</b> .....	
<b>ECU DIAGNOSIS INFORMATION</b> .....	DTC Logic .....	
<b>BCM</b> .....	Diagnosis Procedure .....	
List of ECU Reference .....	<b>C1729 VEHICLE SPEED SIGNAL</b> .....	

Description .....	30	Description .....	42
DTC Logic .....	30	Diagnosis Procedure .....	42
Diagnosis Procedure .....	30		
<b>C1734 BCM .....</b>	<b>31</b>	<b>ID REGISTRATION CANNOT BE COMPLET- ED .....</b>	<b>43</b>
DTC Logic .....	31	Description .....	43
Diagnosis Procedure .....	31	Diagnosis Procedure .....	43
<b>TIRE PRESSURE RECEIVER .....</b>	<b>33</b>	<b>PERIODIC MAINTENANCE .....</b>	<b>44</b>
Component Function Check .....	33		
Diagnosis Procedure .....	33	<b>ROAD WHEEL .....</b>	<b>44</b>
<b>LOW TIRE PRESSURE WARNING LAMP .....</b>	<b>35</b>	Adjustment .....	44
Component Function Check .....	35	<b>REMOVAL AND INSTALLATION .....</b>	<b>47</b>
Diagnosis Procedure .....	35		
<b>POWER SUPPLY AND GROUND CIRCUIT ....</b>	<b>36</b>	<b>ROAD WHEEL TIRE ASSEMBLY .....</b>	<b>47</b>
Diagnosis Procedure .....	36	Exploded View .....	47
<b>SYMPTOM DIAGNOSIS .....</b>	<b>37</b>	Removal and Installation .....	47
		Inspection .....	47
<b>TPMS .....</b>	<b>37</b>	<b>TRANSMITTER .....</b>	<b>49</b>
Symptom Table .....	37	Exploded View .....	49
<b>LOW TIRE PRESSURE WARNING LAMP DOES NOT TURN ON .....</b>	<b>40</b>	Removal and Installation .....	49
Description .....	40	<b>TIRE PRESSURE RECEIVER .....</b>	<b>51</b>
Diagnosis Procedure .....	40	Exploded View .....	51
<b>LOW TIRE PRESSURE WARNING LAMP DOES NOT TURN OFF .....</b>	<b>41</b>	Removal and Installation .....	51
Description .....	41	<b>SERVICE DATA AND SPECIFICATIONS (SDS) .....</b>	<b>52</b>
Diagnosis Procedure .....	41		
<b>LOW TIRE PRESSURE WARNING LAMP BLINKS .....</b>	<b>42</b>	<b>SERVICE DATA AND SPECIFICATIONS (SDS) .....</b>	<b>52</b>
		Road Wheel .....	52
		Tire Air Pressure .....	52

# PRECAUTIONS

< PRECAUTION >

## PRECAUTION

### PRECAUTIONS

#### Precaution for Supplemental Restraint System (SRS) "AIR BAG" and "SEAT BELT PRE-TENSIONER"

INFOID:000000006858104

The Supplemental Restraint System such as "AIR BAG" and "SEAT BELT PRE-TENSIONER", used along with a front seat belt, helps to reduce the risk or severity of injury to the driver and front passenger for certain types of collision. This system includes seat belt switch inputs and dual stage front air bag modules. The SRS system uses the seat belt switches to determine the front air bag deployment, and may only deploy one front air bag, depending on the severity of a collision and whether the front occupants are belted or unbelted. Information necessary to service the system safely is included in the "SRS AIR BAG" and "SEAT BELT" of this Service Manual.

#### **WARNING:**

Always observe the following items for preventing accidental activation.

- To avoid rendering the SRS inoperative, which could increase the risk of personal injury or death in the event of a collision that would result in air bag inflation, all maintenance must be performed by an authorized NISSAN/INFINITI dealer.
- Improper maintenance, including incorrect removal and installation of the SRS, can lead to personal injury caused by unintentional activation of the system. For removal of Spiral Cable and Air Bag Module, see "SRS AIR BAG".
- Never use electrical test equipment on any circuit related to the SRS unless instructed to in this Service Manual. SRS wiring harnesses can be identified by yellow and/or orange harnesses or harness connectors.

#### PRECAUTIONS WHEN USING POWER TOOLS (AIR OR ELECTRIC) AND HAMMERS

#### **WARNING:**

Always observe the following items for preventing accidental activation.

- When working near the Air Bag Diagnosis Sensor Unit or other Air Bag System sensors with the ignition ON or engine running, never use air or electric power tools or strike near the sensor(s) with a hammer. Heavy vibration could activate the sensor(s) and deploy the air bag(s), possibly causing serious injury.
- When using air or electric power tools or hammers, always switch the ignition OFF, disconnect the battery, and wait at least 3 minutes before performing any service.

#### Precautions Necessary for Steering Wheel Rotation After Battery Disconnection

INFOID:000000006858425

#### **CAUTION:**

Comply with the following cautions to prevent any error and malfunction.

- Before removing and installing any control units, first turn the ignition switch to the LOCK position, then disconnect both battery cables.
- After finishing work, confirm that all control unit connectors are connected properly, then re-connect both battery cables.
- Always use CONSULT to perform self-diagnosis as a part of each function inspection after finishing work. If a DTC is detected, perform trouble diagnosis according to self-diagnosis results.

For vehicle with steering lock unit, if the battery is disconnected or discharged, the steering wheel will lock and cannot be turned.

If turning the steering wheel is required with the battery disconnected or discharged, follow the operation procedure below before starting the repair operation.

#### OPERATION PROCEDURE

1. Connect both battery cables.

#### **NOTE:**

Supply power using jumper cables if battery is discharged.

2. Turn the ignition switch to ACC position.  
(At this time, the steering lock will be released.)
3. Disconnect both battery cables. The steering lock will remain released with both battery cables disconnected and the steering wheel can be turned.

# PRECAUTIONS

## < PRECAUTION >

---

4. Perform the necessary repair operation.
5. When the repair work is completed, re-connect both battery cables. With the brake pedal released, turn the ignition switch from ACC position to ON position, then to LOCK position. (The steering wheel will lock when the ignition switch is turned to LOCK position.)
6. Perform self-diagnosis check of all control units using CONSULT.

## Service Notice or Precautions

INFOID:000000006206606

- Low tire pressure warning lamp blinks for 1min, then turns ON when occurring any malfunction except low tire pressure. Delete the memory with CONSULT-III, or register the ID to turn low tire pressure warning lamp OFF. Refer to [WT-10, "AIR PRESSURE MONITOR : CONSULT-III Function \(BCM - AIR PRESSURE MONITOR\)"](#), [WT-22, "Work Procedure"](#).
- ID registration is required when replacing or rotating wheels, replacing transmitter or BCM. Refer to [BCS-82, "Exploded View"](#).
- Replace grommet seal, valve core and cap of transmitter in TPMS every tire replacement by reaching wear limit of tire. Refer to [WT-49, "Exploded View"](#).

# PREPARATION

< PREPARATION >

## PREPARATION

### PREPARATION

#### Special Service Tool

INFOID:000000006206607

The actual shapes of Kent-Moore tools may differ from those of special service tools illustrated here.

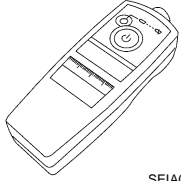
Tool number (Kent-Moore No.) Tool name	Description
- (J-45295) Transmitter activation tool   <p style="text-align: center;">SEIA0462E</p>	ID registration

A  
B  
C  
D  
WT

#### Commercial Service Tool

INFOID:000000006206608

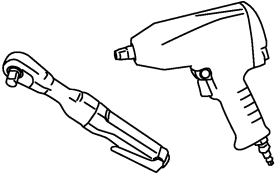
Tool name	Description
Power tool   <p style="text-align: center;">PBIC0190E</p>	Loosening wheel nuts

F  
G  
H  
I  
J  
K  
L  
M  
N  
O  
P

# COMPONENT PARTS

< SYSTEM DESCRIPTION >

## SYSTEM DESCRIPTION

### COMPONENT PARTS

#### Component Parts Location

INFOID:000000006206609

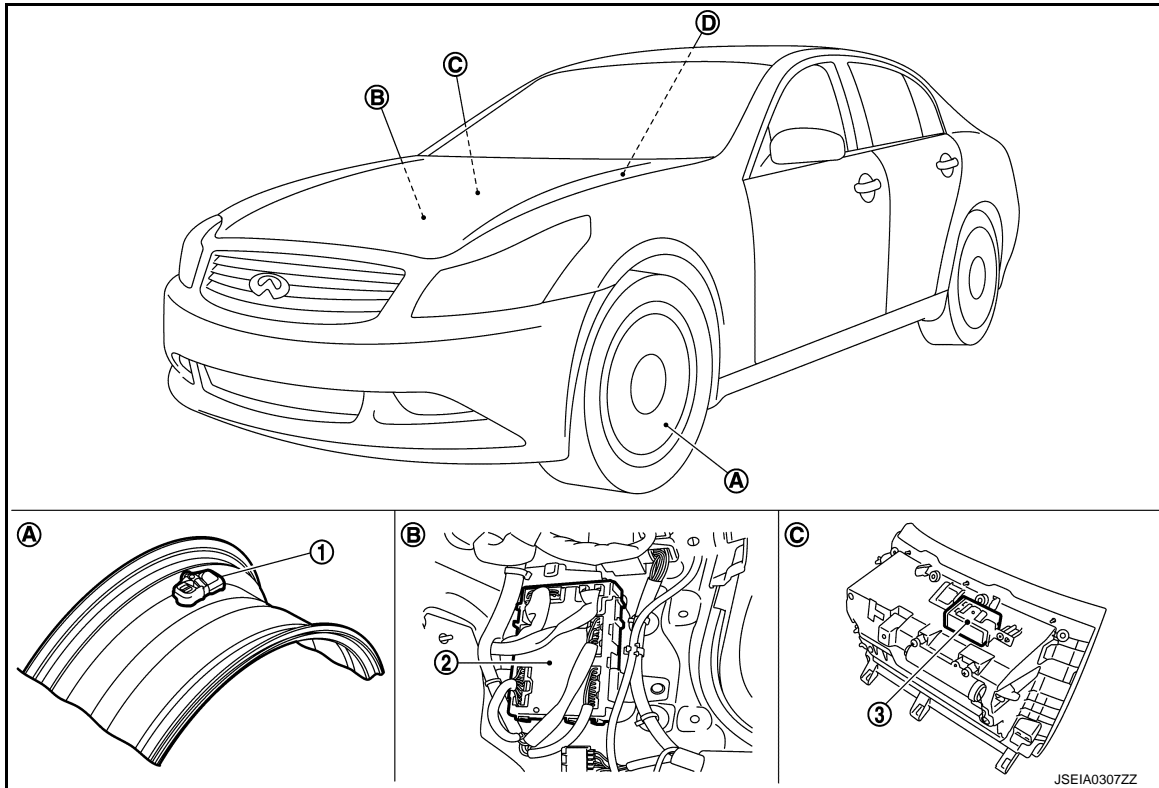

- |   |                                     |                              |
|---|-------------------------------------|------------------------------|
| 1. Transmitter  | 2. BCM                              | 3. Tire pressure receiver    |
| A. Wheel  | B. Dash side lower (passenger side) | C. Instrument lower panel RH |
| D. Low tire pressure warning lamp, information display (in combination meter) |                                     |                              |

#### Component Description

INFOID:000000006206610

Component parts	Function
BCM (Body Control Module)	<a href="#">WT-6. "BCM"</a> .
Transmitter	<a href="#">WT-7. "Transmitter"</a> .
Tire pressure receiver	<a href="#">WT-7. "Tire Pressure Receiver"</a> .
Turn signal lamp	ID registration of each wheel has been completed, turn signal lamp flashes.
	Transmits the vehicle speed signal via CAN communication to BCM.
Unified meter and A/C amp.	Receives the following signals via CAN communication for BCM. <ul style="list-style-type: none"> <li>• Low tire pressure warning lamp signal</li> <li>• TPMS warning lamp signal</li> </ul>
Low tire pressure warning lamp	<a href="#">WT-8. "System Description"</a>
Information display	<a href="#">WT-7. "Information Display"</a>

#### BCM

INFOID:000000006206611

The BCM reads the air pressure signal received by the tire pressure receiver, and controls the low tire pressure warning lamp operation. It also has a judgment function to detect a system malfunction.

# COMPONENT PARTS

## < SYSTEM DESCRIPTION >

### Transmitter

INFOID:000000006206612

The transmitter integrated with a valve is installed on a wheel, and transmits a detected air pressure signal by radio wave.

### Tire Pressure Receiver

INFOID:000000006206613

The tire pressure receiver receives the air pressure signal transmitted by the transmitter in each wheel.

### Information Display

INFOID:000000006571727

The vehicle information display is shown when a low tire pressure warning lamp signal is transmitted from BCM to Unified meter and A/C amp. via CAN communication.

Condition	Vehicle information display
Ignition switch OFF	Non-indication
Low tire pressure	Indication

A  
B  
C  
D  
WT  
F  
G  
H  
I  
J  
K  
L  
M  
N  
O  
P

# SYSTEM

< SYSTEM DESCRIPTION >

## SYSTEM

### System Description

INFOID:000000006206617

During driving, the TPMS (Tire Pressure Monitoring System) receives the signal transmitted from transmitter installed in each wheel. The BCM (Body Control Module) of this system has pressure judgment and trouble diagnosis functions. When the tire pressure monitoring system detects low inflation pressure or another unusual symptom, the low tire pressure warning lamps in the unified meter and A/C amp. comes on.

### SYSTEM DIAGRAM

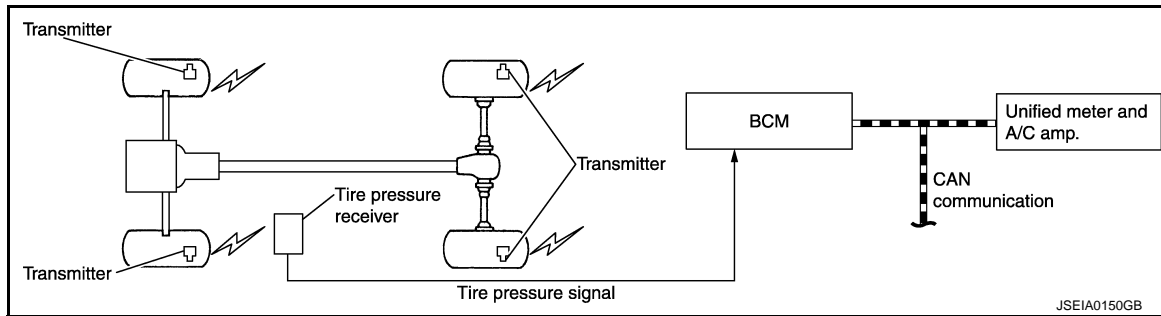

### INPUT/OUTPUT SIGNAL

The signal transmission/reception between units via a communication line is mainly as listed in the following table.

Component parts	Signal item
BCM	Transmits the following signals via CAN communication to unified meter and A/C amp. <ul style="list-style-type: none"> <li>• Low tire pressure warning lamp signal</li> </ul>
Unified meter and A/C amp.	Transmits the vehicle speed signal via CAN communication to BCM.

### LOW TIRE PRESSURE WARNING LAMP INDICATION CONDITION

Uses CAN communication from the BCM to illuminate the low tire pressure warning lamp on the unified meter and A/C amp.

Condition	Low tire pressure warning lamp
Ignition switch OFF	OFF
Ignition switch ON (system normal)	Warning lamp turns on for 1second, then turns off.
Low tire pressure	ON
Transmitter ID not registered in BCM.	ON
Tire pressure monitoring system malfunction (Other diagnostic item)	Warning lamp blinks 1 min, then turns on.
Tire pressure sensor is in OFF state	Blink (Blinking pattern depends on the positions of non-operational tire pressure sensors.)



# DIAGNOSIS SYSTEM (BCM)

< SYSTEM DESCRIPTION >

## DIAGNOSIS SYSTEM (BCM)

### COMMON ITEM

### COMMON ITEM : CONSULT-III Function (BCM - COMMON ITEM)

INFOID:000000006206619

### APPLICATION ITEM

CONSULT-III performs the following functions via CAN communication with BCM.

Diagnosis mode	Function Description
Work Support	Changes the setting for each system function.
Self Diagnostic Result	Displays the diagnosis results judged by BCM.
CAN Diag Support Monitor	Monitors the reception status of CAN communication viewed from BCM. Refer to CONSULT-III operation manual.
Data Monitor	The BCM input/output signals are displayed.
Active Test	The signals used to activate each device are forcibly supplied from BCM.
Ecu Identification	The BCM part number is displayed.
Configuration	This function is not used even though it is displayed.

### SYSTEM APPLICATION

BCM can perform the following functions for each system.

#### NOTE:

It can perform the diagnosis modes except the following for all sub system selection items.

×: Applicable item

System	Sub system selection item	Diagnosis mode		
		Work Support	Data Monitor	Active Test
Door lock	DOOR LOCK	×	×	×
Rear window defogger	REAR DEFOGGER		×	×
Warning chime	BUZZER		×	×
Interior room lamp timer	INT LAMP	×	×	×
Exterior lamp	HEAD LAMP	×	×	×
Wiper and washer	WIPER	×	×	×
Turn signal and hazard warning lamps	FLASHER	×	×	×
—	AIR CONDITONER*			
• Intelligent Key system • Engine start system	INTELLIGENT KEY	×	×	×
Combination switch	COMB SW		×	
Body control system	BCM	×		
IVIS - NATS	IMMU		×	×
Interior room lamp battery saver	BATTERY SAVER	×	×	×
Trunk lid open	TRUNK		×	×
Vehicle security system	THEFT ALM	×	×	×
RAP system	RETAINED PWR		×	
Signal buffer system	SIGNAL BUFFER		×	×
TPMS	TPMS (AIR PRESSURE MONITOR)	×	×	×

#### NOTE:

\*: This item is displayed, but is not used.

### FREEZE FRAME DATA (FFD)

The BCM records the following vehicle condition at the time a particular DTC is detected, and displays on CONSULT-III.

# DIAGNOSIS SYSTEM (BCM)

## < SYSTEM DESCRIPTION >

CONSULT screen item	Indication/Unit	Description	
Vehicle Speed	km/h	Vehicle speed of the moment a particular DTC is detected	
Odo/Trip Meter	km	Total mileage (Odometer value) of the moment a particular DTC is detected	
Vehicle Condition	SLEEP>LOCK	Power position status of the moment a particular DTC is detected	While turning BCM status from low power consumption mode to normal mode (Power supply position is "LOCK")
	SLEEP>OFF		While turning BCM status from low power consumption mode to normal mode (Power supply position is "OFF".)
	LOCK>ACC		While turning power supply position from "LOCK" to "ACC"
	ACC>ON		While turning power supply position from "ACC" to "IGN"
	RUN>ACC		While turning power supply position from "RUN" to "ACC" (Vehicle is stopping and selector lever is except P position.)
	CRANK>RUN		While turning power supply position from "CRANKING" to "RUN" (From cranking up the engine to run it)
	RUN>URGENT		While turning power supply position from "RUN" to "ACC" (Emergency stop operation)
	ACC>OFF		While turning power supply position from "ACC" to "OFF"
	OFF>LOCK		While turning power supply position from "OFF" to "LOCK"
	OFF>ACC		While turning power supply position from "OFF" to "ACC"
	ON>CRANK		While turning power supply position from "IGN" to "CRANKING"
	OFF>SLEEP		While turning BCM status from normal mode (Power supply position is "OFF".) to low power consumption mode
	LOCK>SLEEP		While turning BCM status from normal mode (Power supply position is "LOCK".) to low power consumption mode
	LOCK		Power supply position is "LOCK" (Ignition switch OFF with steering is locked.)
	OFF		Power supply position is "OFF" (Ignition switch OFF with steering is unlocked.)
	ACC		Power supply position is "ACC" (Ignition switch ACC)
	ON		Power supply position is "IGN" (Ignition switch ON with engine stopped)
ENGINE RUN	Power supply position is "RUN" (Ignition switch ON with engine running)		
CRANKING	Power supply position is "CRANKING" (At engine cranking)		
IGN Counter	0 - 39	<p>The number of times that ignition switch is turned ON after DTC is detected</p> <ul style="list-style-type: none"> <li>The number is 0 when a malfunction is detected now.</li> <li>The number increases like 1 → 2 → 3...38 → 39 after returning to the normal condition whenever ignition switch OFF → ON.</li> <li>The number is fixed to 39 until the self-diagnosis results are erased if it is over 39.</li> </ul>	

## AIR PRESSURE MONITOR

### AIR PRESSURE MONITOR : CONSULT-III Function (BCM - AIR PRESSURE MONITOR)

INFOID:000000006206621

#### APPLICATION ITEM

CONSULT-III performs the following functions via CAN communication with BCM.

Diagnosis mode	Function Description
Self Diagnostic Result	Displays the diagnosis results judged by BCM.
Data Monitor	The BCM input/output signals are displayed.
Active Test	The signals used to activate each device are forcibly supplied from BCM.
Work Support	Components can be quickly and accurately adjusted.

# DIAGNOSIS SYSTEM (BCM)

## < SYSTEM DESCRIPTION >

### SELF DIAGNOSTIC RESULT

Refer to [BCS-76. "DTC Index"](#).

When "CRNT" is displayed on self-diagnosis result,

- The system is presently malfunctioning.

When "PAST" is displayed on self-diagnosis result,

- System malfunction in the past is detected, but the system is presently normal.

### DATA MONITOR MODE

Screen of data monitor mode is displayed.

#### NOTE:

When malfunction is detected, CONSULT-III perform REAL-TIME DIAGNOSIS.

Also, any malfunction detected while in this mode will be displayed at real time.

Monitor item (Unit)	Remark
AIR PRESS FL (kPa/kg/cm <sup>2</sup> /Psi)	Tire pressure
AIR PRESS FR (kPa/kg/cm <sup>2</sup> /Psi)	
AIR PRESS RR (kPa/kg/cm <sup>2</sup> /Psi)	
AIR PRESS RL (kPa/kg/cm <sup>2</sup> /Psi)	
ID REGST FL1 (Green/Red)	Registration ID
ID REGST FR1 (Green/Red)	
ID REGST RR1 (Green/Red)	
ID REGST RL1 (Green/Red)	
WARNING LAMP (On/Off)	Low tire pressure warning lamp
BUZZER (On/Off)	<b>NOTE:</b> This item is displayed, but cannot be use this item.

#### NOTE:

Before performing the self-diagnosis, be sure to register the ID, or erase the actual malfunction location may be different from that displayed on CONSULT-III.

### ACTIVE TEST MODE

#### NOTE:

Before performing the self-diagnosis, be sure to register the ID, or erase the actual malfunction may be different from that displayed on CONSULT-III.

### TEST ITEM LIST

Test item	Content
WARNING LAMP	This test is able to check to check that the low tire pressure warning lamp turns on.
ID REGIST WARNING	This test is able to check to check that the low tire pressure warning lamp turns on.
FLASHER	This test is able to check to check that each turn signal lamp turns on.
HORN	This test is able to check to check that the horn sounds.

### WORK SUPPORT MODE

Item	Description
ID READ	Registered tire pressure sensor ID can be displayed.
ID REGIST	Tire pressure sensor ID can be registered.

# BCM

< ECU DIAGNOSIS INFORMATION >

## ECU DIAGNOSIS INFORMATION

### BCM

#### List of ECU Reference

INFOID:000000006206622

ECU	Reference
BCM	<a href="#">BCS-43. "Reference Value"</a>
	<a href="#">BCS-73. "Fail-safe"</a>
	<a href="#">BCS-75. "DTC Inspection Priority Chart"</a>
	<a href="#">BCS-76. "DTC Index"</a>

# TIRE PRESSURE MONITORING SYSTEM

< WIRING DIAGRAM >

## WIRING DIAGRAM

### TIRE PRESSURE MONITORING SYSTEM

#### Wiring Diagram

INFOID:000000006206623

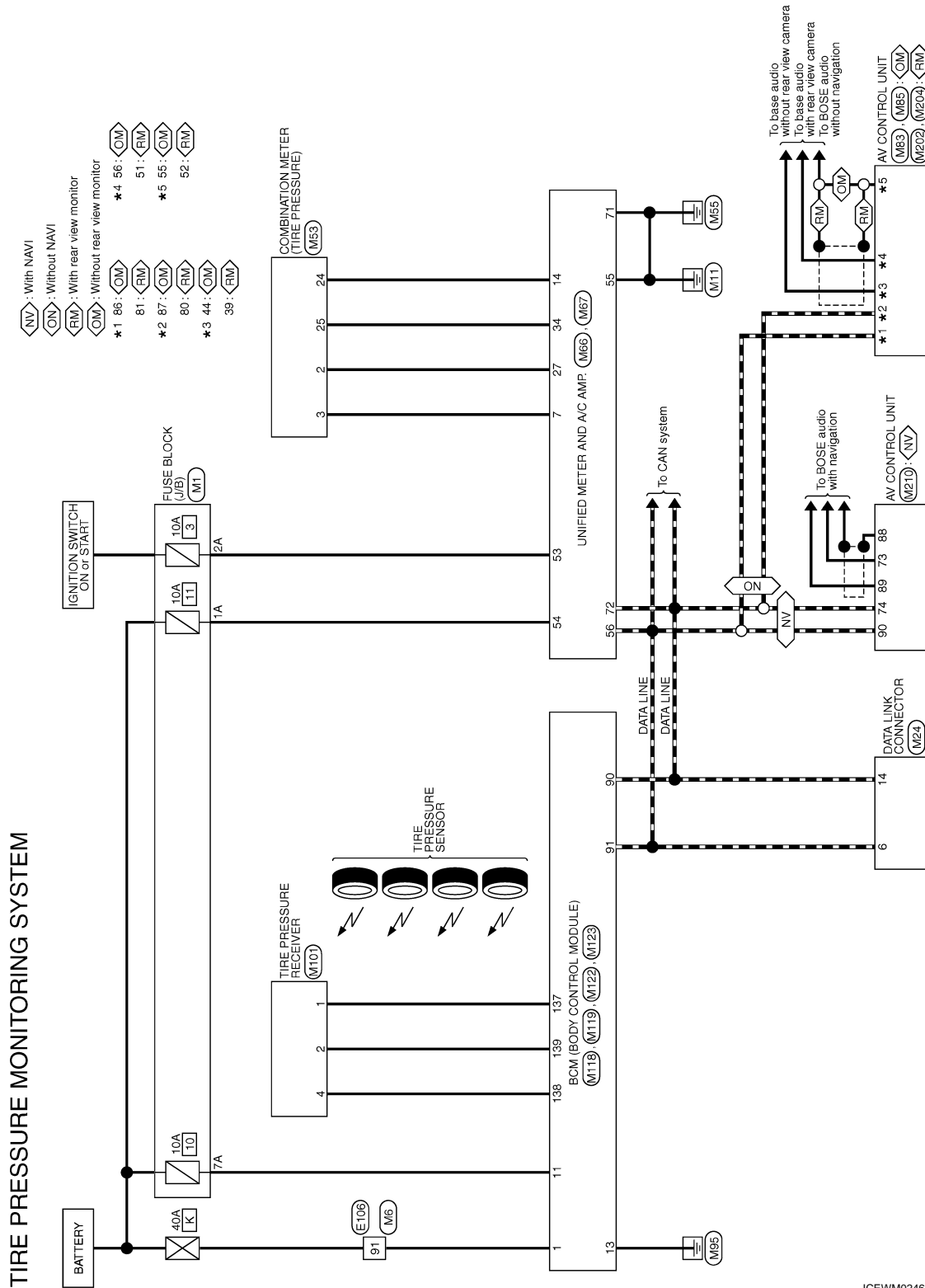

2010/08/18

JCEWM0246GB

A  
B  
C  
D  
E  
F  
G  
H  
I  
J  
K  
L  
M  
N  
O  
P

WT

# TIRE PRESSURE MONITORING SYSTEM

< WIRING DIAGRAM >

## TIRE PRESSURE MONITORING SYSTEM

Connector No.	E106
Connector Name	WIRE TO WIRE
Connector Type	TH80FY-CS16-TM4



Terminal No.	Color of Wire	Signal Name [Specification]
1	GR	-
2	GR	-
3	BG	-
4	Y	-
5	G	-
6	Y	-
7	V	-
8	R	-
9	R	-
10	W	-
11	V	-
12	R	-
13	L	-
14	GR	-
15	P	-
16	W	-
17	SB	-
18	BG	-
19	SB	-
20	LG	-
30	BR	-
31	L	-
32	BG	-
33	P	-
34	V	-
35	W	-
36	SB	-
37	Y	-
38	R	-
39	B	-
40	G	-
41	R	-
42	LG	-
43	G	-
44	GR	-
45	BR	-
46	LG	-
47	V	-
48	P	-
49	L	-
50	B	-

Connector No.	66
Connector Name	GR
Connector Type	-



Terminal No.	Color of Wire	Signal Name [Specification]
1	BG	-
2	R	-
3	R	-
4	G	-
5	GR	-
6	LG	-
7	W	-
8	Y	-
9	G	-
10	W	-
11	V	-
12	R	-
13	L	-
14	GR	-
15	P	-
16	W	-
17	BR	-
18	P	-
19	L	-
20	BR	-
31	L	-
32	Y	-
33	BG	-
34	W	-
35	BR	-
36	R	-
37	Y	-
38	R	-
39	SB	-
40	G	-
41	V	-
42	LG	-
43	P	-
44	B	- [With A/T]
45	R	- [With M/T]
46	BG	-
47	L	-
48	P	-
49	L	-
48	L	-

Connector No.	M1
Connector Name	FUSE BLOCK (J/B)
Connector Type	NS06FY-M2



Terminal No.	Color of Wire	Signal Name [Specification]
1A	V	-
2A	G	-
3A	L	-
4A	P	-
5A	L	-
6A	Y	-
7A	R	-
8A	L	-

Connector No.	M6
Connector Name	WIRE TO WIRE
Connector Type	TH80MW-CS16-TM4

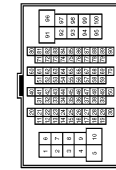

Terminal No.	Color of Wire	Signal Name [Specification]
1	BG	-
2	R	-
3	R	-
4	G	-
5	GR	-
6	LG	-
7	W	-
8	Y	-
9	G	-
10	W	-
11	V	-
12	R	-
13	L	-
14	GR	-
15	P	-
16	W	-
17	BR	-
18	P	-
19	L	-
20	L	-
30	BR	-
31	L	-
32	Y	-
33	BG	-
34	W	-
35	BR	-
36	R	-
37	Y	-
38	R	-
39	SB	-
40	G	-
41	V	-
42	LG	-
43	P	-
44	B	- [With A/T]
45	R	- [With M/T]
46	BG	-
47	L	-
48	P	-
49	L	-
48	L	-

59	B	-
66	Y	-
67	G	-
68	R	-
69	W	-
70	G	-
80	SB	-
81	B	-
82	V	-
83	W	-
84	L	-
85	GR	-
86	G	-
87	R	-
88	B	-
89	LG	-
91	W	-
93	Y	-
95	Y	-
97	GR	-
88	SHIELD	-
99	V	-
100	SB	-

Connector No.	M24
Connector Name	DATA LINK CONNECTOR
Connector Type	BD16FW-P

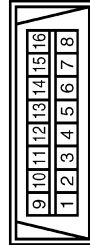

Terminal No.	Color of Wire	Signal Name [Specification]
3	LG	-
4	B	-
5	B	-
6	L	-
7	V	-
8	G	-
11	SB	-
14	P	-
16	R	-

# TIRE PRESSURE MONITORING SYSTEM

< WIRING DIAGRAM >

## TIRE PRESSURE MONITORING SYSTEM

Connector No.	M53
Connector Name	COMBINATION METER
Connector Type	SAB40PW

1	2	3	4	5	6	7	8	9	10	11	12	13	14	15	16	17	18	19	20
21	22	23	24	25	26	27	28	29	30	31	32	33	34	35	36	37	38	39	40

Terminal No.	Color of Wire	Signal Name [Specification]
1	V	BATTERY POWER SUPPLY
2	LG	COMMUNICATION SIGNAL (METER->AMP.)
3	GR	COMMUNICATION SIGNAL (AMP->METER)
5	B	GROUND
6	W	ALTERNATOR SIGNAL
7	LG	AIR BAG SIGNAL
10	W	SECURITY SIGNAL
15	B	GROUND
16	BR	METER CONTROL SWITCH GROUND
18	GR	ILL GND
19	B	ILL GND
20	R	ILL
21	G	IGNITION SIGNAL
22	B	GROUND
24	BR	COMMUNICATION SIGNAL (LCD->AMP.)
25	Y	COMMUNICATION SIGNAL (AMP->LCD)
26	R	VEHICLE SPEED SIGNAL (8-PULSE)
27	P	PARKING BRAKE SWITCH SIGNAL
28	SB	BRAKE FLUID LEVEL SWITCH
29	P	SEAT BELT BUCKLE SW SIGNAL (DRIVER SIDE)
30	G	SEAT BELT BUCKLE SWITCH SIGNAL (PASSENGER SIDE)
31	L	WASHER LEVEL SWITCH SIGNAL
33	R	ILLUMINATION CONTROL SIGNAL
36	LG	SELECT SWITCH SIGNAL
37	Y	ENTER SWITCH SIGNAL
38	G	TRIP A/B RESET SWITCH SIGNAL
39	P	ILLUMINATION CONTROL SWITCH SIGNAL (-)
40	BG	ILLUMINATION CONTROL SWITCH SIGNAL (+)

Connector No.	M66
Connector Name	UNIFIED METER AND A.C. AMP.
Connector Type	TH43PFI-NH

1	2	3	4	5	6	7	8	9	10	11	12	13	14	15	16	17	18	19	20
21	22	23	24	25	26	27	28	29	30	31	32	33	34	35	36	37	38	39	40

Terminal No.	Color of Wire	Signal Name [Specification]
4	G	STOP LAMP SWITCH SIGNAL
5	L	MANUAL MODE SHIFT UP SIGNAL
6	BG	PADDLE SHIFTER UP SIGNAL
7	GR	COMMUNICATION SIGNAL (AMP->METER)
8	L	VEHICLE SPEED SIGNAL (2-PULSE)
9	SB	SEAT BELT BUCKLE SWITCH SIGNAL (DRIVER SIDE)
10	W	MANUAL MODE SIGNAL
11	G	NON-MANUAL MODE SIGNAL
14	BR	COMMUNICATION SIGNAL (LCD->AMP.)
20	BR	ION ON / OFF SIGNAL
23	Y	AT SNOW SWITCH SIGNAL
25	V	MANUAL MODE SHIFT DOWN SIGNAL
26	G	PADDLE SHIFTER DOWN SIGNAL
27	LG	COMMUNICATION SIGNAL (METER->AMP.)
28	R	VEHICLE SPEED SIGNAL (8-PULSE)
30	V	PARKING BRAKE SWITCH SIGNAL
34	Y	COMMUNICATION SIGNAL (AMP->LCD)
38	P	BLOWER MOTOR CONTROL SIGNAL

Connector No.	M67
Connector Name	UNIFIED METER AND A.C. AMP.
Connector Type	TH43PFI-NH

1	2	3	4	5	6	7	8	9	10	11	12	13	14	15	16	17	18	19	20
21	22	23	24	25	26	27	28	29	30	31	32	33	34	35	36	37	38	39	40

Terminal No.	Color of Wire	Signal Name [Specification]
41	L	AGC POWER SUPPLY
42	BR	FUEL LEVEL SENSOR SIGNAL
43	BR	INTAKE SENSOR SIGNAL
44	LG	IN-VEHICLE SENSOR SIGNAL

45	V	AMBIENT SENSOR SIGNAL
46	Y	SUNLOAD SENSOR SIGNAL
47	G	EMERGENCY BRAKE SWITCH SENSOR SIGNAL
53	W	IGNITION POWER SUPPLY
54	SB	BATTERY POWER SUPPLY
55	B	GROUND
56	L	CAV-H
57	LG	BRAKE FLUID LEVEL SWITCH
58	Y	FUEL LEVEL SENSOR GROUND
59	GR	INTAKE SENSOR GROUND
60	W	IN-VEHICLE SENSOR GROUND
61	B	AMBIENT SENSOR GROUND
62	SB	SUNLOAD SENSOR GROUND
63	L	ION CONTROL MODE OUTPUT SIGNAL
65	BG	ECV SIGNAL
69	P	A/C LAN SIGNAL
70	R	EACH DOOR MOTOR POWER SUPPLY
71	GR	GROUND
72	P	CAV-L

47	46	45	44	43	42	41	40	39	38	37	36
59	58	57	56	55	54	53	52	51	50	49	48

Terminal No.	Color of Wire	Signal Name [Specification]
47	BR	COMPOSITE IMAGE SIGNAL
37	Y	COMPOSITE IMAGE GND
38	P	RGB (EBLUE) SIGNAL
39	L	RGB (GGREEN) SIGNAL
40	G	RGB (RFRED) SIGNAL
41	W	RGB SYNC
42	SHIELD	SHIELD
43	B	RGB AREA (YS) SIGNAL
44	L	COMM (DISP->CONT)
45	R	HP
46	LG	SIGNAL GND
47	BG	SIGNAL VCC
48	BR	COMP SYNC
49	Y	SHIELD
50	SHIELD	SHIELD
55	B	SHIELD
56	LG	COMM (CONT->DISP)

Connector No.	M83
Connector Name	AV CONTROL UNIT
Connector Type	TH24FW-NH

47	46	45	44	43	42	41	40	39	38	37	36
59	58	57	56	55	54	53	52	51	50	49	48

Terminal No.	Color of Wire	Signal Name [Specification]
85	B	GND
86	L	CAV-H
87	P	CAV-L
88	SB	AV COMM (H)
89	LG	AV COMM (L)
90	SB	AV COMM (H)
91	LG	AV COMM (L)
95	R	AUX SOUND SIGNAL RH (+)
96	W	AUX SOUND SIGNAL LH (+)
97	B	AUX SOUND SIGNAL GND
101	BR	SW GND
103	V	EJECT SIGNAL
104	G	IGNITION
105	BG	REVERSE
106	SB	PARKING BRAKE
107	R	VEHICLE SPEED (8-PULSE)

57	G	VP
58	BR	INVERTER GND
59	Y	INVERTER VCC

Connector No.	M85
Connector Name	AV CONTROL UNIT
Connector Type	TH432FW-NH



91	89	88	87	86	85	84	83	82	81	80	79	78	77	76	
107	106	105	104	103	102	101	100	99	98	97	96	95	94	93	92

Terminal No.	Color of Wire	Signal Name [Specification]
85	B	GND
86	L	CAV-H
87	P	CAV-L
88	SB	AV COMM (H)
89	LG	AV COMM (L)
90	SB	AV COMM (H)
91	LG	AV COMM (L)
95	R	AUX SOUND SIGNAL RH (+)
96	W	AUX SOUND SIGNAL LH (+)
97	B	AUX SOUND SIGNAL GND
101	BR	SW GND
103	V	EJECT SIGNAL
104	G	IGNITION
105	BG	REVERSE
106	SB	PARKING BRAKE
107	R	VEHICLE SPEED (8-PULSE)

A  
B  
C  
D  
WT  
F  
G  
H  
I  
J  
K  
L  
M  
N  
O  
P

# TIRE PRESSURE MONITORING SYSTEM

< WIRING DIAGRAM >

## TIRE PRESSURE MONITORING SYSTEM

Connector No.	M101
Connector Name	TIRE PRESSURE RECEIVER
Connector Type	TKQAFW

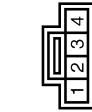

Terminal No.	Color of Wire	Signal Name [Specification]
1	P	GND
2	L	SIGNAL
4	V	BATTERY

Connector No.	M118
Connector Name	BCM (BODY CONTROL MODULE)
Connector Type	MD3FB-LC



Terminal No.	Color of Wire	Signal Name [Specification]
1	W	BAT (E/L)
2	Y	POWER WINDOW POWER SUPPLY (BAT)
3	BG	POWER WINDOW POWER SUPPLY (RAP)

Connector No.	M119
Connector Name	BCM (BODY CONTROL MODULE)
Connector Type	NS16FW-CS



Terminal No.	Color of Wire	Signal Name [Specification]
--------------	---------------	-----------------------------

4	LG	INTERIOR ROOM LAMP POWER SUPPLY
5	P	PASSENGER DOOR UNLOCK OUTPUT
7	SB	STEP LAMP OUTPUT
8	V	ALL DOOR FUEL LID LOCK OUTPUT
9	G	DRIVER DOOR FUEL LID UNLOCK OUTPUT
10	P	REAR DOOR UNLOCK OUTPUT
11	R	BAT (FUSE)
13	B	GND
14	W	PUSH-BUTTON IGNITION SW ILL GND
15	BG	ACC IND
17	W	TURN SIGNAL RH (FRONT)
18	BG	TURN SIGNAL LH (FRONT)
19	V	INT ROOM LAMP CONT

Connector No.	M122
Connector Name	BCM (BODY CONTROL MODULE)
Connector Type	TH4QFB-NH



Terminal No.	Color of Wire	Signal Name [Specification]
72	R	ROOM ANT 2-
73	G	ROOM ANT 2+
74	SB	PASSENGER DOOR ANT-
75	BR	PASSENGER DOOR ANT+
76	V	DRIVER DOOR ANT-
77	LG	DRIVER DOOR ANT+
78	Y	ROOM ANT 1-
79	BR	ROOM ANT 1+
80	GR	IMTS ANT AMP
81	W	IMTS ANT AMP
82	SB	IGN RELAY (F/B) CONT
83	Y	KEYLESS ENTRY RECEIVER COMM
87	Y	COMBI SW INPUT 5
88	BG	COMBI SW INPUT 3
89	BR	PUSH SW
90	P	CAN-L
91	L	CAN-H
92	LG	KEY SLOT ILL
93	GR	ON IND
95	BG	ACC RELAY CONT
96	GR	A.T SHIFT SELECTOR POWER SUPPLY
97	L	S/L CONDITION 1
98	P	S/L CONDITION 2

99	R	SHIFT P. (With A.T)
99	BR	ASCO CLUTCH SW (With M.T)
100	Y	PASSENGER DOOR REQUEST SW
101	P	DRIVER DOOR REQUEST SW
102	BG	BLOWER FAN MOTOR RELAY CONT
103	P	KEYLESS ENTRY RECEIVER POWER SUPPLY
106	SB	S.T. UNIT POWER SUPPLY
107	LG	COMBI SW INPUT 1
108	R	COMBI SW INPUT 4
109	W	COMBI SW INPUT 2
110	G	HAZARD SW
111	Y	S.L UNIT COMM

Connector No.	M123
Connector Name	BCM (BODY CONTROL MODULE)
Connector Type	TH4QFG-NH



Terminal No.	Color of Wire	Signal Name [Specification]
112	R	RAIN SENSOR SERIAL LINK
113	BG	OPTICAL SENSOR
114	R	CLUTCH INTERLOCK SW
116	SB	STOP LAMP SW 1
118	BR	STOP LAMP SW 2
119	SB	DR DOOR UNLOCK SENSOR
121	SB	IGN F/B
123	V	KEY SLOT SW
124	B	PASSENGER DOOR SW
129	BG	TRUNK LID OPENER CANCEL SW
132	V	POWER WINDOW SW COMM
133	L	PUSH-BUTTON IGNITION SW ILL POWER
134	LG	LOCK IND
137	BG	RECEIVER / SENSOR GND
138	V	RECEIVER / SENSOR POWER SUPPLY
139	L	TIRE PRESSURE RECEIVER COMM
140	B	SHIFT N/P
141	W	SECURITY INDICATOR LAMP
142	BR	COMBI SW OUTPUT 5
143	P	COMBI SW OUTPUT 1
144	G	COMBI SW OUTPUT 2
145	L	COMBI SW OUTPUT 3
146	SB	COMBI SW OUTPUT 4
150	GR	DRIVER DOOR SW

Terminal No.	Color of Wire	Signal Name [Specification]
151	G	REAR WINDOW DEFOGGER RELAY CONT

Connector No.	M202
Connector Name	AV CONTROL UNIT
Connector Type	TH24FW-NH

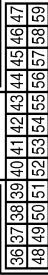

Terminal No.	Color of Wire	Signal Name [Specification]
36	BG	SIGNAL VCC
37	LG	SIGNAL GND
38	R	HP
39	L	COMM (DISP->CONT)
40	B	RGB AREA (Y/S) SIGNAL
41	SHIELD	SHIELD
42	W	RGB SYNC
43	G	RGB (RR) SIGNAL
44	L	RGB (G) SIGNAL
45	P	RGB (BB) SIGNAL
46	Y	COMPOSITE IMAGE GND
47	BR	COMPOSITE IMAGE SIGNAL
48	Y	INVERTER VCC
49	BR	INVERTER GND
50	G	VP
51	P	COMM (CONT->DISP)
52	SHIELD	SHIELD
57	SHIELD	SHIELD
58	SHIELD	SHIELD



# TIRE PRESSURE MONITORING SYSTEM

< WIRING DIAGRAM >

## TIRE PRESSURE MONITORING SYSTEM

Connector No.	M204
Connector Name	AV CONTROL UNIT
Connector Type	TH22PV-NH



76	77	78	79	80	81	82	83	84	85	86	87	88	89	90	91
82	83	84	85	86	87	88	89	90	91	92	93	94	95	96	97

Terminal No.	Color of Wire	Signal Name [Specification]
76	LG	AV COMM (L)
77	SB	AV COMM (H)
78	LG	AV COMM (L)
79	SB	AV COMM (H)
80	P	CAN-L
81	L	CAN-H
82	BR	SW GND
86	SHIELD	SHIELD
87	L	TEL VOICE SIGNAL (+)
88	P	TEL VOICE SIGNAL (-)
92	R	VEHICLE SPEED (8-PULSE)
93	SB	PARKING BRAKE
94	BG	REVERSE
95	G	IGNITION
96	V	DISK EJECT SIGNAL

Connector No.	M210
Connector Name	AV CONTROL UNIT
Connector Type	TH22PV-NH



61	62	63	64	65	66	67	68	69	70	71	72	73	74	75	76
77	78	79	80	81	82	83	84	85	86	87	88	89	90	91	92

Terminal No.	Color of Wire	Signal Name [Specification]
65	SB	PARKING BRAKE
67	P	COMPOSITE IMAGE GND
68	L	COMPOSITE IMAGE SIGNAL
71	SHIELD	MICROPHONE GND
72	G	MICROPHONE VCC
73	P	COMM (CONT->DISP)
74	P	CAN-L

75	LG	AV COMM (L)
76	LG	AV COMM (L)
79	L	ILLUMINATION
80	G	IGNITION
81	BG	REVERSE
82	R	VEHICLE SPEED (8-PULSE)
83	SHIELD	SHIELD
87	R	MICROPHONE SIGNAL
88	SHIELD	SHIELD
89	L	COMM (DISP->CONT)
90	L	CAN-H
91	SB	AV COMM (H)
92	SB	AV COMM (H)

A  
B  
C  
D  
WT  
F  
G  
H  
I  
J  
K  
L  
M  
N  
O  
P

JCEWM0250GB

# DIAGNOSIS AND REPAIR WORK FLOW

< BASIC INSPECTION >

## BASIC INSPECTION

### DIAGNOSIS AND REPAIR WORK FLOW

#### Work Flow

INFOID:000000006206624

#### DETAILED FLOW

#### 1. COLLECT THE INFORMATION FROM THE CUSTOMER

It is also important to clarify customer concerns before starting the inspection. Reproduce the symptom, and understand it fully. Interview the customer about the concerns carefully. In some cases, it is necessary to check the symptoms by driving the vehicle with the customer.

**CAUTION:**

**Customers are not professionals. Never assume “maybe the customer means...” or “maybe the customer mentioned this symptom.**

>> GO TO 2.

#### 2. BASIC INSPECTION

1. Turn the ignition switch ON.

**CAUTION:**

**Never start the engine.**

2. Check the tire pressure for all wheels and adjust to the specified value. Refer to [WT-52. "Tire Air Pressure"](#).

Is the inspection result normal?

YES >> GO TO 3.

NO >> Inspect or repair the tires or wheels.

#### 3. CHECK LOW TIRE PRESSURE WARNING LAMP

Check low tire pressure warning lamp display.

Does not low tire pressure warning lamp turn OFF?

YES >> GO TO 4.

NO >> INSPECTION END

#### 4. CRUISE TEST

Start the engine and drive the vehicle.

>> GO TO 5.

#### 5. PERFORM SELF-DIAGNOSIS

 **With CONSULT-III**

Perform “SELF-DIAG RESULTS” in “AIR PRESSURE MONITOR” of “BCM”.

Is any DTC detected?

YES >> GO TO 7.

NO >> GO TO 6.

#### 6. CHECK SYMPTOM

Perform trouble diagnosis for the applicable symptom. Refer to [WT-37. "Symptom Table"](#).

Is the cause of the malfunction detected?

YES >> GO TO 8.

NO >> GO TO 10.

#### 7. CIRCUIT DIAGNOSIS

Inspect the malfunctioning system indicated by the DTC code that is detected during self-diagnosis. Refer to [BCS-76. "DTC Index"](#).

>> GO TO 8.

# DIAGNOSIS AND REPAIR WORK FLOW

< BASIC INSPECTION >

---

## 8. REPAIR WORK

---

Repair or replace the malfunctioning part.

>> GO TO 9.

---

## 9. PERFORM SELF-DIAGNOSIS

---

1. Select "SELF-DIAG RESULTS" in "AIR PRESSURE MONITOR" of "BCM".
2. Touch "ERASE" on CONSULT-III screen to erase memory.
3. Drive the vehicle.
4. Perform "SELF-DIAG RESULTS" in "AIR PRESSURE MONITOR" of "BCM".

Is any DTC detected?

- YES >> GO TO 7.  
NO >> GO TO 10.

---

## 10. FINAL CHECK

---

1. Perform a cruise test.
2. Check that the low tire pressure warning lamp turn OFF.

Dose the tire pressure warning lamp turn OFF?

- YES >> INSPECTION END  
NO >> GO TO 2.

A  
B  
C  
D  
WT  
F  
G  
H  
I  
J  
K  
L  
M  
N  
O  
P

## ADDITIONAL SERVICE WHEN REPLACING BCM

< BASIC INSPECTION >

---

### ADDITIONAL SERVICE WHEN REPLACING BCM

#### Description

INFOID:000000006570174

When replacing BCM, transmitter ID registration is required.

#### Work Procedure

INFOID:000000006570175

#### 1. PERFORM TRANSMITTER ID REGISTRATION

---

Perform transmitter ID registration.

>> Refer to [WT-22. "Work Procedure"](#).

# TRANSMITTER WAKE UP OPERATION

< BASIC INSPECTION >

## TRANSMITTER WAKE UP OPERATION

### Description

INFOID:000000006206625

This procedure must be done after replacement of a transmitter, BCM, or rotation of wheels.

### Work Procedure

INFOID:000000006206626

#### 1. TRANSMITTER WAKE-UP PROCEDURE

1. Turn the ignition switch ON.

**CAUTION:**

**Never start the engine.**

**NOTE:**

The position of an inactive transmitter can be identified by checking the blinking timing of the low tire pressure warning lamp.

Low tire pressure warning lamp blinking timing		Activation tire position
ON OFF		a : 0.3 sec. b : 1.0 sec. Front LH
ON OFF		a : 0.3 sec. b : 1.0 sec. Front RH
ON OFF		a : 0.3 sec. b : 1.0 sec. Rear RH
ON OFF		a : 0.3 sec. b : 1.0 sec. Rear LH
ON OFF		a : 2 sec. b : 0.2 sec. All tires

JPEIC0089GB

2. Contact the transmitter activation tool (J-45295) (1) to the side of the tire at the location to the transmitter.
3. Press and hold the activation tool button while pushing the tool to the tire surface. (approximately for 5 seconds)

**CAUTION:**

**Perform the wake-up procedure starting from the vehicle front left wheel, then repeat the procedure in the order of the front right wheel, rear right wheel, and rear left wheel.**

4. Check that the turn signal lamps blink twice when the transmitter wake-up procedure for all wheels is completed.
5. Check that the low tire pressure warning lamp turns OFF, after the transmitter wake-up procedure is completed for all wheels and turns OFF.

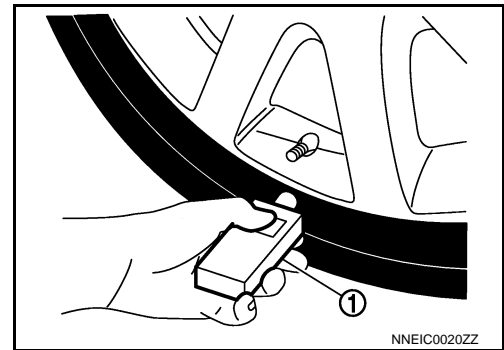

NNEIC0020ZZ

Is the transmitter wake-up procedure completed?

- YES >> Perform the transmitter ID registration procedure. Refer to [WT-22, "Work Procedure"](#).  
 NO >> Perform trouble diagnosis for the transmitter. Refer to [WT-26, "Diagnosis Procedure"](#).

# ID REGISTRATION

< BASIC INSPECTION >

## ID REGISTRATION

### Description

INFOID:000000006206627

This procedure must be done after replacing or rotating wheels, replacing transmitter or BCM.

### Work Procedure

INFOID:000000006206628

#### 1. TRANSMITTER ID REGISTRATION PROCEDURE

Ⓜ With CONSULT-III.

1. Display the "WORK SUPPORT" screen and select "ID REGIST".

Is the transmitter activation tool (J-45295) used for the transmitter ID registration procedure?

YES >> GO TO 2.

NO >> GO TO 3.

#### 2. TRANSMITTER ID REGISTRATION PROCEDURE (WITH TRANSMITTER ACTIVATION TOOL)

1. Turn the ignition switch ON.
2. Select the start button on the "ID REGIST" screen.
3. Contact the transmitter activation tool (J-45295) (1) to the side of the tire at the location to the transmitter.
4. Press and hold the activation tool button while pushing the tool to the tire surface. (approximately for 5 seconds)

**CAUTION:**

**Perform the ID registration procedure starting from the vehicle front left wheel, then repeat the procedure in the order of the front right wheel, rear right wheel, and rear left wheel.**

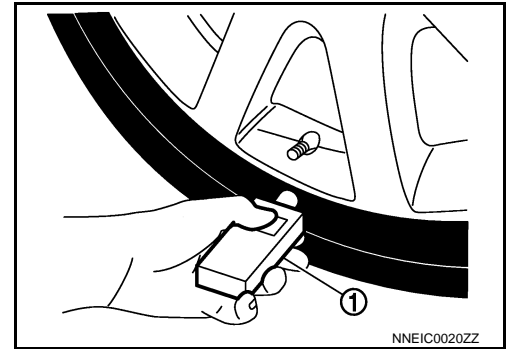

5. When ID registration is completed, check the following pattern at each wheel.

Se-quence	ID registration position	Turn signal lamp	CONSULT-III
1	Front left wheel	2 blinks	"Red" ↓ "Green"
2	Front right wheel		
3	Rear right wheel		
4	Rear left wheel		

6. After the ID registration procedure for all wheels is completed, press "END" to end ID registration, and check that ID registration for all wheels is completed.

Is the check result normal?

YES >> ID registration END.

NO >> Performs trouble-diagnosis of the Tire Pressure Monitoring System (TPMS). Refer to [BCS-76](#), "[DTC Index](#)".

#### 3. TRANSMITTER ID REGISTRATION PROCEDURE (WITHOUT TRANSMITTER ACTIVATION TOOL)

1. Adjust the tire pressure for all wheels to match the list below.

Tire position	Tire pressure kPa (kg/cm <sup>2</sup> , psi)
Front LH	240 (2.4, 35)
Front RH	220 (2.2, 31)
Rear RH	200 (2.0, 29)
Rear LH	180 (1.8, 26)

# ID REGISTRATION

< BASIC INSPECTION >

2. Drive the vehicle at a speed at more than 40 km/h (25 MPH) for 3 minutes or more, then perform the transmitter ID registration procedure.
3. After ID registration for all wheels is completed, press "END" to end ID registration.

A  
B  
C  
D  
WT  
F  
G  
H  
I  
J  
K  
L  
M  
N  
O  
P

ID registration position	CONSULT-III
Front LH	"Red" ↓ "Green"
Front RH	
Rear RH	
Rear LH	

4. Adjust the tire pressures for all wheels to the specified value. Refer to [WT-52. "Tire Air Pressure"](#).

Is ID registrations for all wheels completed?

- YES >> ID registration END.  
 NO >> Performs trouble-diagnosis of the Tire Pressure Monitoring System (TPMS). Refer to [BCS-76. "DTC Index"](#).

WT

# C1704, C1705, C1706, C1707 LOW TIRE PRESSURE

< DTC/CIRCUIT DIAGNOSIS >

## DTC/CIRCUIT DIAGNOSIS

### C1704, C1705, C1706, C1707 LOW TIRE PRESSURE

#### Description

INFOID:000000006206629

When the tire pressure monitoring system detects low inflation pressure, the low tire pressure warning lamps in the combination meter comes on.

#### DTC Logic

INFOID:000000006206630

#### DTC DETECTION LOGIC

DTC	Display item	Malfunction detected condition	Possible cause
C1704	LOW PRESSURE FL	Front LH tire pressure drops to * kPa (* kg/cm <sup>2</sup> , * psi) or less. [NOTE]	• Low tire pressure • Transmitter malfunction
C1705	LOW PRESSURE FR	Front RH tire pressure drops to * kPa (* kg/cm <sup>2</sup> , * psi) or less. [NOTE]	
C1706	LOW PRESSURE RR	Rear RH tire pressure drops to * kPa (* kg/cm <sup>2</sup> , * psi) or less. [NOTE]	
C1707	LOW PRESSURE RL	Rear LH tire pressure drops to * kPa (* kg/cm <sup>2</sup> , * psi) or less. [NOTE]	

\*: 182.7 kPa (1.9 kg/cm<sup>2</sup>, 26 psi): Standard air pressure is for 230 kPa (2.3 kg/cm<sup>2</sup>, 33 psi) vehicles.

#### DTC CONFIRMATION PROCEDURE

##### 1. DTC REPRODUCTION PROCEDURE

Ⓜ With CONSULT-III

1. Turn the ignition switch ON.

**CAUTION:**

**Never start the engine.**

2. Check the tire pressure for all wheels and adjust to the specified value. Refer to [WT-52, "Tire Air Pressure"](#).

3. Perform "SELF-DIAG RESULTS" in "AIR PRESSURE MONITOR" of "BCM".

Is DTC "C1704", "C1705", "C1706", "C1707" detected?

YES >> Perform trouble diagnosis. Refer to [WT-24, "Diagnosis Procedure"](#).

NO >> INSPECTION END

#### Diagnosis Procedure

INFOID:000000006206631

##### 1. CHECK TIRE PRESSURE

Check the internal pressure of all wheels. Refer to [WT-52, "Tire Air Pressure"](#).

Is the inspection result normal?

YES >> Replace the DTC-detected malfunctioning transmitter. Refer to [WT-49, "Exploded View"](#).

NO >> After adjusting the air pressure, GO TO 2.

##### 2. CHECK TIRE PRESSURE SIGNAL

Ⓜ With CONSULT-III

1. Drive for 3 minutes at a speed of 40 km/h (25 MPH) or more, then drive normally for 10 minutes.

2. Perform "DATA MONITOR" in "AIR PRESSURE MONITOR" of "BCM".

3. Select "BCM" in "DATA MONITOR", and check that the tire pressures match the standard value.

Monitor item	Condition	Displayed value
AIR PRESS FL	Drive for 3 minutes at a speed of 40 km/h (25 MPH) or more, then drive normally for 10 minutes.	Internal pressure of tires
AIR PRESS FR		
AIR PRESS RR		
AIR PRESS RL		

**CAUTION:**



## C1704, C1705, C1706, C1707 LOW TIRE PRESSURE

< DTC/CIRCUIT DIAGNOSIS >

**Stop the vehicle and within 5 minutes, use “DATA MONITOR” in “AIR PRESSURE MONITOR” of “BCM” to display the tire pressure for all wheels.**

Is the inspection result normal?

YES >> Inspect or repair the tires or wheels and adjust the tire pressure to the specification.

NO >> GO TO 1.

A

B

C

D

WT

F

G

H

I

J

K

L

M

N

O

P

# C1708, C1709, C1710, C1711 TRANSMITTER

< DTC/CIRCUIT DIAGNOSIS >

## C1708, C1709, C1710, C1711 TRANSMITTER

### DTC Logic

INFOID:000000006206633

#### DTC DETECTION LOGIC

DTC	Display item	Malfunction detected condition	Possible cause
C1708	[NO DATA] FL	Tire pressure data signal from the front left wheel transmitter cannot be detected.	<ul style="list-style-type: none"> <li>• Harness or connector (Tire pressure receiver, BCM)</li> <li>• ID registration is not finished</li> <li>• Transmitter malfunction</li> <li>• BCM malfunction</li> </ul>
C1709	[NO DATA] FR	Tire pressure data signal from the front right wheel transmitter cannot be detected.	
C1710	[NO DATA] RR	Tire pressure data signal from the rear right wheel transmitter cannot be detected.	
C1711	[NO DATA] RL	Tire pressure data signal from the rear left wheel transmitter cannot be detected.	

#### DTC CONFIRMATION PROCEDURE

##### 1. DTC REPRODUCTION PROCEDURE

Ⓜ With CONSULT-III

1. Drive for 3 minutes at a speed of 40 km/h (25 MPH) or more, then drive normally for 10 minutes.
2. Perform "SELF-DIAG RESULTS" in "AIR PRESSURE MONITOR" of "BCM".

Is DTC "C1708", "C1709", "C1710", "C1711" detected?

- YES >> Perform trouble diagnosis. Refer to [WT-26, "Diagnosis Procedure"](#).  
 NO >> INSPECTION END

#### Diagnosis Procedure

INFOID:000000006206634

##### 1. CHECK TIRE PRESSURE SIGNAL

Ⓜ With CONSULT-III

1. Drive for 3 minutes at a speed of 40 km/h (25 MPH) or more, then drive normally for 10 minutes.
2. Perform "DATA MONITOR" in "AIR PRESSURE MONITOR" of "BCM".
3. Select "BCM" in "DATA MONITOR", and check that the tire pressures match the standard value.

Monitor item	Condition	Displayed value
AIR PRESS FL	Drive for 3 minutes at a speed of 40 km/h (25 MPH) or more, then drive normally for 10 minutes.	Internal pressure of tires
AIR PRESS FR		
AIR PRESS RR		
AIR PRESS RL		

#### CAUTION:

**Stop the vehicle and within 5 minutes, use "DATA MONITOR" in "AIR PRESSURE MONITOR" of "BCM" to display the tire pressure for all wheels.**

Is a tire pressure of 0 kPa (0 Psi) displayed for all wheels?

- YES >> GO TO 2.  
 NO >> GO TO 5.

##### 2. CHECK HARNESS BETWEEN BCM AND TIRE PRESSURE RECEIVER

1. Turn the ignition switch OFF.
2. Disconnect BCM harness connector and tire pressure receiver harness connector.
3. Check the continuity between BCM harness connector and tire pressure receiver harness connector.

# C1708, C1709, C1710, C1711 TRANSMITTER

## < DTC/CIRCUIT DIAGNOSIS >

BCM		Tire pressure receiver		Continuity
Connector	Terminal	Connector	Terminal	
M123	137	M101	1	Existed
	138		4	
	139		2	

4. Check the continuity between BCM harness connector and ground.

BCM		—	Continuity
Connector	Terminal		
M123	137	Ground	Not existed
	138		
	139		

Is the inspection result normal?

YES >> GO TO 3.

NO >> Repair or replace damaged parts.

### 3. CHECK TIRE PRESSURE RECEIVER POWER SUPPLY CIRCUIT

1. Connect the BCM harness connector.

2. Turn the ignition switch ON.

**CAUTION:**

**Never start the engine.**

3. Check the voltage between the BCM harness connector and ground.

BCM		—	Voltage
Connector	Terminal		
M123	138	Ground	5 V

Is the inspection result normal?

YES >> GO TO 4.

NO >> Repair or replace damaged parts.

### 4. CHECK TIRE PRESSURE RECEIVER

Check tire pressure receiver. Refer to [WT-33, "Diagnosis Procedure"](#).

Is the inspection result normal?

YES >> GO TO 5.

NO >> Replace tire pressure receiver. Refer to [WT-51, "Exploded View"](#).

### 5. CHECK ID REGISTRATION

Perform ID registration of all transmitters. Refer to [WT-22, "Work Procedure"](#).

Can ID registration of all transmitters be completed?

YES >> GO TO 6.

NO >> Replace transmitter. Refer to [WT-49, "Exploded View"](#).

### 6. CHECK TIRE PRESSURE MONITORING SYSTEM

Ⓜ With CONSULT-III

1. Drive at a speed of 40 km/h (25 MPH) or more for several minutes without stopping.

2. Perform "DATA MONITOR" in "AIR PRESSURE MONITOR" of "BCM".

3. Select "BCM" in "DATA MONITOR", and check that the tire pressures match the standard value.

## C1708, C1709, C1710, C1711 TRANSMITTER

### < DTC/CIRCUIT DIAGNOSIS >

Monitor item	Condition	Displayed value
AIR PRESS FL	Drive at a speed of 40 km/h (25 MPH) or more, for several minutes without stopping.	Internal pressure of tires
AIR PRESS FR		
AIR PRESS RR		
AIR PRESS RL		

**CAUTION:**

Stop the vehicle and within 15 minutes, use “DATA MONITOR” in “AIR PRESSURE MONITOR” of “BCM” to read the tire pressure for all wheels.

Is the inspection result normal?

- YES >> Replace the DTC-detected malfunctioning transmitter. Refer to [WT-49. "Exploded View"](#).  
NO >> Replace BCM. Refer to [BCS-82. "Exploded View"](#).

# C1716, C1717, C1718, C1719 TRANSMITTER

< DTC/CIRCUIT DIAGNOSIS >

## C1716, C1717, C1718, C1719 TRANSMITTER

### DTC Logic

INFOID:000000006206636

### DTC DETECTION LOGIC

DTC	Display item	Malfunction detected condition	Possible case
C1716	[PRESSDATA ERR] FL	Malfunction in the tire pressure data from the front left wheel transmitter.	<ul style="list-style-type: none"><li>• ID registration is not finished</li><li>• Transmitter malfunction</li></ul>
C1717	[PRESSDATA ERR] FR	Malfunction in the tire pressure data from the front right wheel transmitter.	
C1718	[PRESSDATA ERR] RR	Malfunction in the tire pressure data from the rear right wheel transmitter.	
C1719	[PRESSDATA ERR] RL	Malfunction in the tire pressure data from the rear left wheel transmitter.	

### DTC CONFIRMATION PROCEDURE

#### 1. DTC REPRODUCTION PROCEDURE

Ⓜ With CONSULT-III

1. Turn the ignition switch ON.

**CAUTION:**

**Never start the engine.**

2. Check the tire pressure for all wheels and adjust to the specified value. Refer to [WT-52, "Tire Air Pressure"](#).
3. Perform "SELF-DIAG RESULTS" in "AIR PRESSURE MONITOR" of "BCM".

Is DTC "C1716", "C1717", "C1718", "C1719" detected?

- YES >> Perform trouble diagnosis. Refer to [WT-29, "Diagnosis Procedure"](#).  
NO >> INSPECTION END

### Diagnosis Procedure

INFOID:000000006206637

#### 1. CHECK TIRE PRESSURE

Check the internal pressure of all wheels. Refer to [WT-52, "Tire Air Pressure"](#).

Is the inspection result normal?

- YES >> Replace the DTC-detected malfunctioning transmitter. Refer to [WT-49, "Exploded View"](#).  
NO >> After adjusting the tire pressure, GO TO 2.

#### 2. CHECK TIRE PRESSURE SIGNAL

Ⓜ With CONSULT-III

1. Check and adjust the tire pressure for all wheels. Refer to [WT-52, "Tire Air Pressure"](#).
2. Perform transmitter ID registration for all wheels. Refer to [WT-22, "Work Procedure"](#).
3. Drive for 3 minutes at a speed of 40 km/h (25 MPH) or more, then drive normally for 10 minutes.
4. Perform "DATA MONITOR" in "AIR PRESSURE MONITOR" of "BCM".
5. Select "BCM" in "DATA MONITOR", and check that the tire pressures match the standard value.

**CAUTION:**

**Stop the vehicle and within 15 minutes, use CONSULT-III "DATA MONITOR" to display the tire pressure for all wheels.**

6. Check that "DATA MONITOR" displays tire pressure of 438.60 kPa (4.47 kg/cm<sup>2</sup>, 63.60 Psi).

Is the inspection 438.60 kPa (4.47 kg/cm<sup>2</sup>, 63.60 Psi)?

- YES >> Replace transmitter the tire pressure 438.60 kPa (4.47 kg/cm<sup>2</sup>, 63.60 Psi) displayed. Refer to [WT-49, "Exploded View"](#).  
NO >> GO TO 1.

# C1729 VEHICLE SPEED SIGNAL

< DTC/CIRCUIT DIAGNOSIS >

## C1729 VEHICLE SPEED SIGNAL

### Description

INFOID:000000006206639

BCM detects no vehicle speed signal.

### DTC Logic

INFOID:000000006206640

### DTC DETECTION LOGIC

DTC number	Trouble diagnosis name	DTC detecting condition	Possible case
C1729	VHCL SPEED SIG ERR	Vehicle speed signal not detected.	<ul style="list-style-type: none"><li>CAN communication error</li><li>Unified meter and A/C amp. malfunction</li></ul>

### DTC CONFIRMATION PROCEDURE

#### 1. DTC REPRODUCTION PROCEDURE

Ⓟ With CONSULT-III

- Drive for several minutes at a speed of 40 km/h (25 MPH) or more, then stop the vehicle.
- Perform "SELF-DIAG RESULTS" in "AIR PRESSURE MONITOR" of "BCM".

Is DTC "C1729" detected?

- YES >> Perform trouble diagnosis. Refer to [WT-30, "Diagnosis Procedure"](#).  
NO >> INSPECTION END

### Diagnosis Procedure

INFOID:000000006206641

#### 1. PERFORM UNIFIED METER AND A/C AMP. SELF-DIAGNOSIS

Ⓟ With CONSULT-III

Perform "SELF-DIAG RESULTS" of "METER/M&A".

Is any DTC detected?

- YES >> Check the DTC. Refer to [MWI-107, "DTC Index"](#).  
NO >> GO TO 2.

#### 2. PERFORM SELF-DIAGNOSIS

Ⓟ With CONSULT-III

Perform "SELF-DIAG RESULTS" in "AIR PRESSURE MONITOR" of "BCM".

Is DTC "C1729" detected?

- YES >> Replace BCM. Refer to [WT-9, "COMMON ITEM : CONSULT-III Function \(BCM - COMMON ITEM\)"](#).  
NO >> GO TO 3.

#### 3. CHECK INFORMATION

Ⓟ With CONSULT-III

- Perform "DATA MONITOR" in "AIR PRESSURE MONITOR" of "BCM".
- Select "BCM" in "DATA MONITOR", and check the input/output values. Refer to [BCS-43, "Reference Value"](#).

Is the inspection result normal?

- YES >> Check pin terminal and connection of each harness connector for malfunctioning conditions.  
NO >> Replace BCM. Refer to [BCS-82, "Exploded View"](#).

# C1734 BCM

< DTC/CIRCUIT DIAGNOSIS >

## C1734 BCM

### DTC Logic

INFOID:000000006206643

### DTC DETECTION LOGIC

DTC	Display item	Malfunction detected condition	Possible case
C1734	CONTROL UNIT	Tire pressure monitoring system malfunction in BCM	BCM malfunction

### DTC CONFIRMATION PROCEDURE

#### 1. DTC REPRODUCTION PROCEDURE

④ With CONSULT-III

1. Drive at a speed of 40 km/h (25 MPH) or more for several minutes without stopping.
2. Perform "SELF-DIAG RESULTS" in "AIR PRESSURE MONITOR" of "BCM".

**CAUTION:**

**Perform within 15 minutes after stop the vehicle.**

Is DTC "C1734" detected?

- YES >> Perform trouble diagnosis. Refer to [WT-31, "Diagnosis Procedure"](#).  
 NO >> INSPECTION END

### Diagnosis Procedure

INFOID:000000006206644

#### 1. CHECK BCM POWER SUPPLY

1. Turn the ignition switch OFF.
2. Disconnect BCM harness connector.
3. Check voltage between BCM harness connector terminals and ground.

BCM		—	Voltage
Connector	Terminal		
M118	1	Ground	Battery voltage
M119	11		

Is the power supply normal?

- YES >> GO TO 2.  
 NO >> Check the following. If any items are damaged, repair or replace damage parts.
- 40A fusible link [No. K located in the fuse block]. Refer to [PG-126, "Fuse and Fusible Link Arrangement"](#).
  - 10A fuse [No. 10 located in the fuse block (J/B)]. Refer to [PG-125, "Fuse, Connector and Terminal Arrangement"](#).
  - Harness for short or open between battery and BCM harness connector M118 terminal 1.
  - Harness for short or open between battery and BCM harness connector M119 terminal 11.
  - Check the Battery voltage.

#### 2. CHECK BCM GROUND

Check the continuity between BCM harness connector and ground.

BCM		—	Continuity
Connector	Terminal		
M119	13	Ground	Existed

Is the inspection result normal?

- YES >> GO TO 3.  
 NO >> Repair or replace damaged parts.

#### 3. CHECK HARNESS BETWEEN BCM AND TIRE PRESSURE RECEIVER

1. Disconnect tire pressure receiver harness connector.
2. Check the continuity between BCM harness connector and tire pressure receiver harness connector.

# C1734 BCM

## < DTC/CIRCUIT DIAGNOSIS >

BCM		Tire pressure receiver		Continuity
Connector	Terminal	Connector	Terminal	
M123	137	M101	1	Existed
	138		4	
	139		2	

3. Check the continuity between BCM harness connector and ground.

BCM		—	Continuity
Connector	Terminal		
M123	137	Ground	Not existed
	138		
	139		

Is the inspection result normal?

YES >> GO TO 4.

NO >> Repair or replace damaged parts.

### 4.CHECK BCM

Check the BCM input/output signal. Refer to [BCS-43, "Reference Value"](#).

Is the inspection result normal?

YES >> INSPECTION END

NO >> GO TO 5.

### 5.CHECK BCM HARNESS CONNECTOR

Check the BCM pin terminals for damage or loose connection with harness connector.

Is the inspection result normal?

YES >> Replace BCM. Refer to [BCS-82, "Exploded View"](#).

NO >> Check for looseness or damage at the harness connector pins of the BCM. Repair or replace if necessary.



# TIRE PRESSURE RECEIVER

< DTC/CIRCUIT DIAGNOSIS >

## TIRE PRESSURE RECEIVER

### Component Function Check

INFOID:000000006206646

#### 1. TIRE PRESSURE MONITORING SYSTEM OPERATION

④ With CONSULT-III

1. Drive for 3 minutes at a speed of 40 km/h (25 MPH) or more, then drive normally for 10 minutes.
2. On "DATA MONITOR", select "AIR PRESS FL", "AIR PRESS FR", "AIR PRESS RR" and "AIR PRESS RL", and check that the tire pressures match the standard value.

Monitor item	Condition	Displayed value
AIR PRESS FL	Drive for 3 minutes at a speed of 40 km/h (25 MPH) or more, then drive normally for 10 minutes.	Internal pressure of tires
AIR PRESS FR		
AIR PRESS RR		
AIR PRESS RL		

#### CAUTION:

Stop the vehicle and within 5 minutes, use CONSULT-III "DATA MONITOR" to display the tire pressure for all wheels.

Is the inspection result normal?

YES >> INSPECTION END

NO >> Perform trouble diagnosis. Refer to [WT-33, "Diagnosis Procedure"](#).

### Diagnosis Procedure

INFOID:000000006206647

#### 1. CHECK TIRE PRESSURE RECEIVER SIGNAL

1. Turn the ignition switch ON.

#### CAUTION:

Never start the engine.

2. Check tire pressure receiver connector and ground signal with oscilloscope.

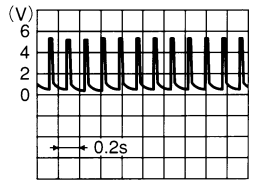
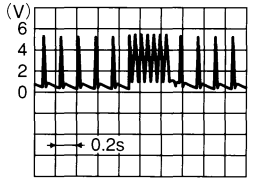
Tire pressure receiver		—	Condition	Voltage (Approx.)
Connector	Terminal			
M101	2	Ground	Stand by state	 <p>OCC3881D</p>
			When receiving the signal from the transmitter	 <p>OCC3880D</p>

Is the inspection result normal?

YES >> INSPECTION END

NO >> GO TO 2.

#### 2. CHECK TIRE PRESSURE RECEIVER INPUT VOLTAGE

1. Disconnect tire pressure receiver connector.
2. Check voltage between tire pressure receiver connector and ground.

# TIRE PRESSURE RECEIVER

## < DTC/CIRCUIT DIAGNOSIS >

Tire pressure receiver		—	Voltage (Approx.)
Connector	Terminal		
M101	4	Ground	5.0 V

Is the inspection result normal?

YES >> GO TO 3.

NO >> Repair or replace damaged parts.

### 3.CHECK TIRE PRESSURE RECEIVER GROUND CIRCUIT

1. Disconnect BCM harness connector.
2. Check continuity between BCM harness connector and tire pressure receiver connector.

BCM		Tire pressure receiver		Continuity
Connector	Terminal	Connector	Terminal	
M123	137	M101	1	Existed

3. Check continuity between BCM harness connector and ground.

BCM		—	Continuity
Connector	Terminal		
M123	137	Ground	Not existed

Is the inspection result normal?

YES >> GO TO 4.

NO >> Repair or replace damaged parts.

### 4.CHECK BCM CIRCUIT

Inspect the BCM circuit. Refer to [WT-31, "Diagnosis Procedure"](#).

Is the BCM circuit normal?

YES >> Replace tire pressure receiver. Refer to [WT-51, "Exploded View"](#).

NO >> Replace BCM. Refer to [BCS-82, "Exploded View"](#).

# LOW TIRE PRESSURE WARNING LAMP

< DTC/CIRCUIT DIAGNOSIS >

## LOW TIRE PRESSURE WARNING LAMP

### Component Function Check

INFOID:000000006206650

#### 1. CHECK THE ILLUMINATION OF THE LOW TIRE PRESSURE WARNING LAMP

Check that the low tire pressure warning lamp is turned OFF after illuminating for approximately 1 second, when the ignition switch is turned ON.

Is the inspection result normal?

YES >> INSPECTION END

NO >> Perform trouble diagnosis. Refer to [WT-35. "Diagnosis Procedure"](#).

### Diagnosis Procedure

INFOID:000000006206651

#### 1. POWER SUPPLY AND GROUND CIRCUIT

Check power supply and ground circuit. Refer to [WT-36. "Diagnosis Procedure"](#).

Is the inspection result normal?

YES >> GO TO 2.

NO >> Repair or replace damaged parts.

#### 2. PERFORM SELF-DIAGNOSIS

Ⓜ With CONSULT-III

Perform "SELF-DIAG RESULTS" in "AIR PRESSURE MONITOR" of "BCM".

Is any DTC detected?

YES >> Check the DTC. Refer to [BCS-76. "DTC Index"](#).

NO >> GO TO 3.

#### 3. CHECK LOW TIRE PRESSURE WARNING LAMP SIGNAL

Ⓜ With CONSULT-III

1. Turn the ignition switch ON.

**CAUTION:**

**Never start the engine.**

2. Perform "DATA MONITOR" in "AIR PRESSURE MONITOR" of "BCM".

3. Select "BCM" in "DATA MONITOR", and check that the low tire pressure warning lamp is turned OFF after illuminating for approximately 1 second, when the ignition switch is turned ON.

Is the inspection result normal?

YES >> Check the combination meter. Refer to [MWI-6. "METER SYSTEM : System Description"](#).

NO >> Replace the BCM. Refer to [BCS-82. "Exploded View"](#).

A  
B  
C  
D  
WT  
F  
G  
H  
I  
J  
K  
L  
M  
N  
O  
P

# POWER SUPPLY AND GROUND CIRCUIT

< DTC/CIRCUIT DIAGNOSIS >

## POWER SUPPLY AND GROUND CIRCUIT

### Diagnosis Procedure

INFOID:000000006206652

#### 1. POWER SUPPLY SYSTEM CHECK

1. Turn the ignition switch OFF.
2. Disconnect the BCM harness connector.
3. Turn the ignition switch ON.  
**CAUTION:**  
**Never start the engine.**
4. Check the voltage between the BCM harness connector and the ground.

BCM		—	Voltage
Connector	Terminal		
M118	1	Ground	Battery voltage
M119	11		

Is the inspection result normal?

- YES >> GO TO 2.  
NO >> Repair or replace damaged parts.

#### 2. GROUND SYSTEM INSPECTION

1. Turn the ignition switch OFF.
2. Check the continuity between the BCM harness connector and the ground.

BCM		—	Continuity
Connector	Terminal		
M119	13	Ground	Existed

Is the inspection result normal?

- YES >> • Check the 10 A fuse [No. 10 in fuse block (J/B)].  
• Check the 40 A fusible link [No. K in fuse block].  
NO >> Repair or replace damaged parts.

< SYMPTOM DIAGNOSIS >

---

# SYMPTOM DIAGNOSIS

TPMS

Symptom Table

INFOID:000000006206653

LOW TIRE PRESSURE WARNING LAMP SYMPTOM CHART

A

B

C

D

**WT**

F

G

H

I

J

K

L

M















N

O

P

# TPMS

## < SYMPTOM DIAGNOSIS >

Diagnosis items	Symptom (Ignition switch ON)	Low tire pressure warning lamp	Cause	Action
Low tire pressure warning lamp	The low tire pressure warning lamp illuminates for 1 second, then turns OFF.	  ON 1 sec > stays OFF <small>SEIA0592E</small>	Wake-up operation for all transmitters at wheels is completed.	No system malfunctions
	The low tire pressure warning lamp repeats blinking ON for 2 seconds and OFF for 0.2 seconds.	 Blinks:  ON 2 sec > OFF 0.2 sec <small>SEIA0593E</small>	Wake-up operation for all transmitters at wheels is not completed.	Perform the wake-up operation for all transmitters at wheels. Refer to <a href="#">WT-21, "Work Procedure"</a> .
	The low tire pressure warning lamp blinks once.	 Blinks 1 time ON 0.3 sec > OFF 1.0 sec <small>JPEIC0090GB</small>	The front left transmitter is not activated.	Perform the wake-up operation for the transmitter at front left wheel. Refer to <a href="#">WT-21, "Work Procedure"</a> .
	The low tire pressure warning lamp repeats blinking twice.	  Blinks 2 times ON 0.3 sec > OFF 0.3 sec <small>SEIA0595E</small>	The front right transmitter is not activated.	Perform the wake-up operation for the transmitter at front right wheel. Refer to <a href="#">WT-21, "Work Procedure"</a> .
	The low tire pressure warning lamp repeats blinking for 3 times.	   Blinks 3 times ON 0.3 sec > OFF 0.3 sec <small>SEIA0596E</small>	The rear right transmitter is not activated.	Perform the wake-up operation for the transmitter at rear right wheel. Refer to <a href="#">WT-21, "Work Procedure"</a> .
	The low tire pressure warning lamp repeats blinking for 4 times.	    Blinks 4 times ON 0.3 sec > OFF 0.3 sec <small>SEIA0597E</small>	The rear left transmitter is not activated.	Perform the wake-up operation for the transmitter at rear left wheel. Refer to <a href="#">WT-21, "Work Procedure"</a> .
	The low tire pressure warning lamp turns ON and stays illuminated.	 Comes ON and stays ON <small>SEIA0598E</small>	Low tire pressure	Check the tire pressure for all wheels and adjust to the specified value. Refer to <a href="#">WT-52, "Tire Air Pressure"</a> .

# TPMS

## < SYMPTOM DIAGNOSIS >

Diagnosis items	Symptom (Ignition switch ON)	Low tire pressure warning lamp	Cause	Action
Low tire pressure warning lamp	The low tire pressure warning lamp repeats blinking at 0.5-second intervals for 1 minute, and then stays illuminated.	 <p style="text-align: center;">Blinks 1 min</p> <p style="text-align: center;">ON 0.5 sec &gt; OFF 0.5 sec and stays ON</p> <p style="text-align: center;"><small>SEIA0788E</small></p>	The combination meter fuse is open or removed (or pulled out).	Check and install the combination meter fuse. If necessary, replace the fuse.
			The BCM harness connector is removed.	Check the connection conditions of the BCM harness connector, and repair if necessary.
			Tire Pressure Monitoring System (TPMS) malfunction.	<ul style="list-style-type: none"> <li>Perform CONSULT-III self-diagnosis. Refer to <a href="#">WT-9</a>, "COMMON ITEM : CONSULT-III Function (BCM - COMMON ITEM)".</li> <li>If necessary, perform transmitter ID registration. Refer to <a href="#">WT-22</a>, "Work Procedure".</li> </ul>
Hazard warning lamp	The hazard warning lamp does not blink twice when the transmitter is activated.	—	<ol style="list-style-type: none"> <li>The transmitter activation tool (J-45295) does not activate.</li> <li>The ignition switch is OFF when the transmitter wake-up operation is performed.</li> <li>The transmitter activation tool (J-45295) is not used in the correct position.</li> <li>The transmitter is already waked up.</li> </ol>	<ol style="list-style-type: none"> <li>Replace the battery in the transmitter activation tool (J-45295).</li> <li>Turn the ignition switch ON when performing the transmitter wake-up operation.</li> <li>Operate the transmitter activation tool (J-45295) in the correct position when performing the wake-up operation.</li> <li>No procedure.</li> </ol>

**NOTE:**

If transmitter wake-up operation is not completed for two or more transmitters, the applicable low tire pressure warning lamp blinking patterns are displayed continuously.  
 (Example: Blinks once/OFF/blinks 3 times = Wake-up operation is not completed at the front left wheel and rear right wheel transmitters.)

A  
B  
C  
D  
WT  
F  
G  
H  
I  
J  
K  
L  
M  
N  
O  
P

# LOW TIRE PRESSURE WARNING LAMP DOES NOT TURN ON

< SYMPTOM DIAGNOSIS >

---

## LOW TIRE PRESSURE WARNING LAMP DOES NOT TURN ON

### Description

INFOID:000000006206654

The low tire pressure warning lamp does not illuminate when the ignition switch is turned ON.

#### **NOTE:**

The low tire pressure warning lamp illuminates for approximately 1 second and then turns OFF when the ignition switch is turned ON. This is to check that no abnormal condition is present in the tire pressure monitoring system.

The lamp bulb may be burnt out or the tire pressure monitoring system may be malfunctioning if the low tire pressure warning lamp does not illuminate when the ignition switch is turned ON.

### Diagnosis Procedure

INFOID:000000006206655

#### **1.**CHECK LOW TIRE PRESSURE WARNING LAMP

---

Perform trouble diagnosis of the low tire pressure warning lamp. Refer to [WT-35, "Diagnosis Procedure"](#).

Is the inspection result normal?

- YES >> Check pin terminal and connection of each connector for damage and loose connection.
- NO >> Repair or replace damaged parts.



# LOW TIRE PRESSURE WARNING LAMP DOES NOT TURN OFF

< SYMPTOM DIAGNOSIS >

## LOW TIRE PRESSURE WARNING LAMP DOES NOT TURN OFF

### Description

INFOID:000000006206656

The low tire pressure warning lamp does not turn OFF after several seconds is passed after engine starts.

### Diagnosis Procedure

INFOID:000000006206657

#### 1. CHECK TIRE PRESSURE

1. Turn the ignition switch ON.

**CAUTION:**

**Never start the engine.**

2. Check the tire pressure for all wheels and adjust to the specified value. Refer to [WT-52, "Tire Air Pressure"](#).

Is the inspection result normal?

YES >> GO TO 2.

NO >> Inspect or repair the tires or wheels.

#### 2. CHECK LOW TIRE PRESSURE WARNING LAMP

Check low tire pressure warning lamp display.

Does not low tire pressure warning lamp turn OFF?

YES >> GO TO 3.

NO >> INSPECTION END

#### 3. CHECK BCM

 With CONSULT-III

Perform "SELF-DIAG RESULTS" in "AIR PRESSURE MONITOR" of "BCM".

Is any DTC detected?

YES >> Check the DTC. Refer to [BCS-76, "DTC Index"](#).

NO >> GO TO 4.

#### 4. CHECK BCM POWER SUPPLY AND GROUND CIRCUIT

Perform the trouble diagnosis for power supply and ground circuit. Refer to [WT-36, "Diagnosis Procedure"](#).

Is the inspection result normal?

YES >> Replace BCM. Refer to [BCS-82, "Exploded View"](#).

NO >> Repair or replace error-detected parts.

A  
B  
C  
D  
WT  
F  
G  
H  
I  
J  
K  
L  
M  
N  
O  
P

# LOW TIRE PRESSURE WARNING LAMP BLINKS

< SYMPTOM DIAGNOSIS >

## LOW TIRE PRESSURE WARNING LAMP BLINKS

### Description

INFOID:000000006206658

The low tire pressure warning lamp blinks when the ignition switch is turned ON.

**NOTE:**

The position of an inactive transmitter can be identified by checking the blinking timing of the low tire pressure warning lamp.

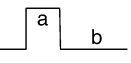
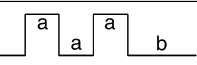
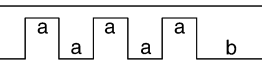
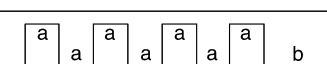
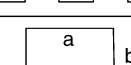
Low tire pressure warning lamp blinking timing		Activation tire position
ON  OFF	a : 0.3 sec. b : 1.0 sec.	Front LH
ON  OFF	a : 0.3 sec. b : 1.0 sec.	Front RH
ON  OFF	a : 0.3 sec. b : 1.0 sec.	Rear RH
ON  OFF	a : 0.3 sec. b : 1.0 sec.	Rear LH
ON  OFF	a : 2 sec. b : 0.2 sec.	All tires

JPEIC0089GB

### Diagnosis Procedure

INFOID:000000006206659

#### 1. TRANSMITTER WAKE-UP OPERATION

Perform the transmitter wake-up. Refer to [WT-21, "Work Procedure"](#).

Is the transmitter wake-up completed?

YES >> GO TO 2.

NO >> Perform trouble diagnosis for the transmitter. Refer to [WT-26, "Diagnosis Procedure"](#).

#### 2. TRANSMITTER ID REGISTRATION

Perform transmitter ID registration. Refer to [WT-22, "Work Procedure"](#).

Is transmitter ID registration completed?

YES >> INSPECTION END

NO >> Perform the self-diagnosis for "AIR PRESSURE MONITOR". Refer to [BCS-76, "DTC Index"](#).

# ID REGISTRATION CANNOT BE COMPLETED

< SYMPTOM DIAGNOSIS >

## ID REGISTRATION CANNOT BE COMPLETED

### Description

INFOID:000000006206662

The ID of the transmitter installed in each wheel cannot be registered in the tire pressure monitoring system. Inspect the transmitter or the tire pressure monitoring system circuit.

### Diagnosis Procedure

INFOID:000000006206663

#### 1. TRANSMITTER WAKE-UP

Perform the transmitter wake-up. Refer to [WT-21, "Work Procedure"](#).

Is the transmitter wake-up completed?

YES >> GO TO 3.

NO >> GO TO 2.

#### 2. CHECK ACTIVATION TOOL

Check activation tool.

Is the inspection result normal?

YES >> GO TO 3.

NO >> Replace battery for activation tool, or repair or replace activation tool.

#### 3. TRANSMITTER ID REGISTRATION

Perform transmitter ID registration. Refer to [WT-22, "Work Procedure"](#).

Is transmitter ID registration completed?

YES >> GO TO 4.

NO >> Change the work location and perform ID registration again.

#### 4. CHECK TIRE PRESSURE SIGNAL

##### With CONSULT-III

1. Drive for 3 minutes at a speed of 40 km/h (25 MPH) or more, then drive normally for 10 minutes.
2. Stop the vehicle.
3. Select "DATA MONITOR" for "AIR PRESSURE MONITOR" with CONSULT-III.
4. Within 5 minutes after vehicle stopped, check that the tire pressures match the standard value.

Monitor item	Displayed value
AIR PRESS FL	Approximately equal to the indication on tire gauge value for front LH tire
AIR PRESS FR	Approximately equal to the indication on tire gauge value for front RH tire
AIR PRESS RR	Approximately equal to the indication on tire gauge value for rear RH tire
AIR PRESS RL	Approximately equal to the indication on tire gauge value for rear LH tire

Is the inspection result normal?

YES >> INSPECTION END

NO >> Change the work location, then GO TO 3.

# ROAD WHEEL

< PERIODIC MAINTENANCE >

## PERIODIC MAINTENANCE

### ROAD WHEEL

#### Adjustment

INFOID:000000006206666

#### BALANCING WHEELS (BONDING WEIGHT TYPE)

##### Preparation Before Adjustment

Using releasing agent, remove double-faced adhesive tape from the road wheel.

##### **CAUTION:**

- **Be careful not scratch the road wheel during removal.**
- **After removing double-faced adhesive tape, wipe clean traces of releasing agent from the road wheel.**

##### Wheel Balance Adjustment

- If a tire balance machine has adhesion balance weight mode settings and drive-in weight mode setting, select and adjust a drive-in weight mode suitable for road wheels.

1. Set road wheel on tire balance machine using the center hole as a guide. Start the tire balance machine.
2. When inner and outer unbalance values are shown on the tire balance machine indicator, multiply outer unbalance value by  $5/3$  to determine balance weight that should be used. Select the outer balance weight with a value closest to the calculated value above and install in to the designated outer position of, or at the designated angle in relation to the road wheel.

##### **CAUTION:**

- **Never install the inner balance weight before installing the outer balance weight.**
- **Before installing the balance weight, be sure to clean the mating surface of the road wheel.**

- a. Indicated un balance value  $\times 5/3 =$  balance weight to be installed

##### **Calculation example:**

$23 \text{ g (0.81 oz)} \times 5/3 = 38.33 \text{ g (1.35 oz)} \Rightarrow 37.5 \text{ g (1.32 oz)}$  balance weight (closer to calculated balance weight value)

##### **NOTE:**

Note that balance weight value must be closer to the calculated balance weight value.

##### **Example:**

$36.2 \Rightarrow 35 \text{ g (1.23 oz)}$

$36.3 \Rightarrow 37.5 \text{ g (1.32 oz)}$

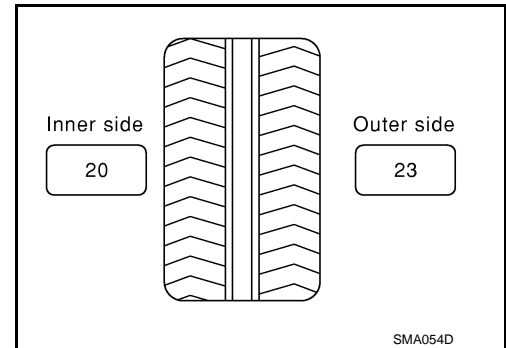

- b. Installed balance weight in the position.

# ROAD WHEEL

## < PERIODIC MAINTENANCE >

- When installing balance weight (1) to road wheels, set it into the grooved area (A) on the inner wall of the road wheel as shown in the figure so that the balance weight center (B) is aligned with the tire balance machine indication position (angle) (C).

**CAUTION:**

- Always use genuine NISSAN adhesion balance weights.
- Balance weights are non-reusable; always replace with new ones.
- Never install more than three sheets of balance weight.

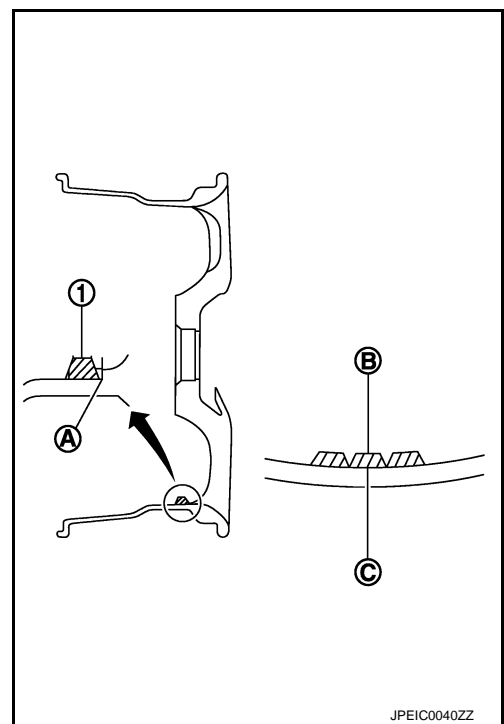

- If calculated balance weight value exceeds 50 g (1.76 oz), install two balance weight sheets in line with each other as shown in the figure.

**CAUTION:**

**Never install one balance weight sheet on top another.**

- Start tire balance machine again.
- Install drive-in balance weight on inner side of road wheel in the tire balance machine indication position (angle).

**CAUTION:**

**Never install more than two balance weight.**

- Start tire balance machine. Make sure that inner and outer residual unbalance values are 5 g (0.17 oz) each or below.
- If either residual unbalance value exceeds 5 g (0.17 oz), repeat installation procedures.

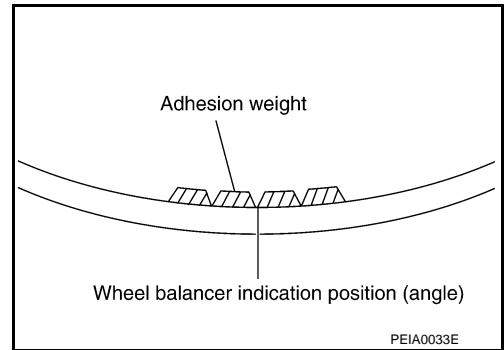

Wheel balance	Dynamic (At flange)	Static (At flange)
Maximum allowable unbalance	Refer to <a href="#">WT-52, "Road Wheel"</a> .	

## TIRE ROTATION (for 17 and 18 inch wheel models)

- Follow the maintenance schedule for tire rotation service intervals. Refer to [MA-5, "Explanation of General Maintenance"](#).
- When installing the wheel, tighten wheel nuts to the specified torque.

**CAUTION:**

- Never include the T-type spare tire when rotating the tires.
- When installing wheels, tighten them diagonally by dividing the work two to three times in order to prevent the wheels from developing any distortion.
- Be careful not to tighten wheel nut at torque exceeding the criteria for preventing strain of disc rotor.
- Use NISSAN genuine wheel nuts for aluminum wheels.

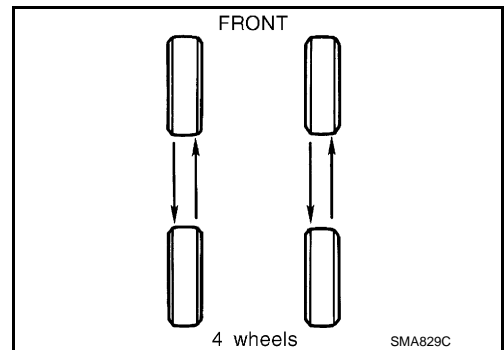

**Wheel nuts tightening torque** : Refer to [WT-52, "Road Wheel"](#).

# ROAD WHEEL

## < PERIODIC MAINTENANCE >

- Perform the ID registration, after tire rotation. Refer to [WT-22. "Work Procedure"](#).

## TIRE ROTATION (for 18 inch front and rear different tire size models)

- Tire cannot be rotated in vehicle, as front tire are different size from rear tire is fixed in each tire.

**Wheel nuts tightening torque** : Refer to [WT-52. "Road Wheel"](#).

### CAUTION:

- **Never include the T-type spare tire when rotating the tires.**
- **Use NISSAN genuine wheel nuts for aluminum wheels.**

Safety Device Preventing from Being Incorrectly installed

### FRONT BRAKE DISC ROTOR AND FRONT WHEEL

- Front and rear wheel size for this model differs, therefore special pin (1) is adopted to the front brake disc rotor (2). And a hole (3) that matches to this pin is adopted to the front wheel (4) (the rear wheel does not have this wheel). This structure prevents the rear wheel from being mistakenly installed on the front.

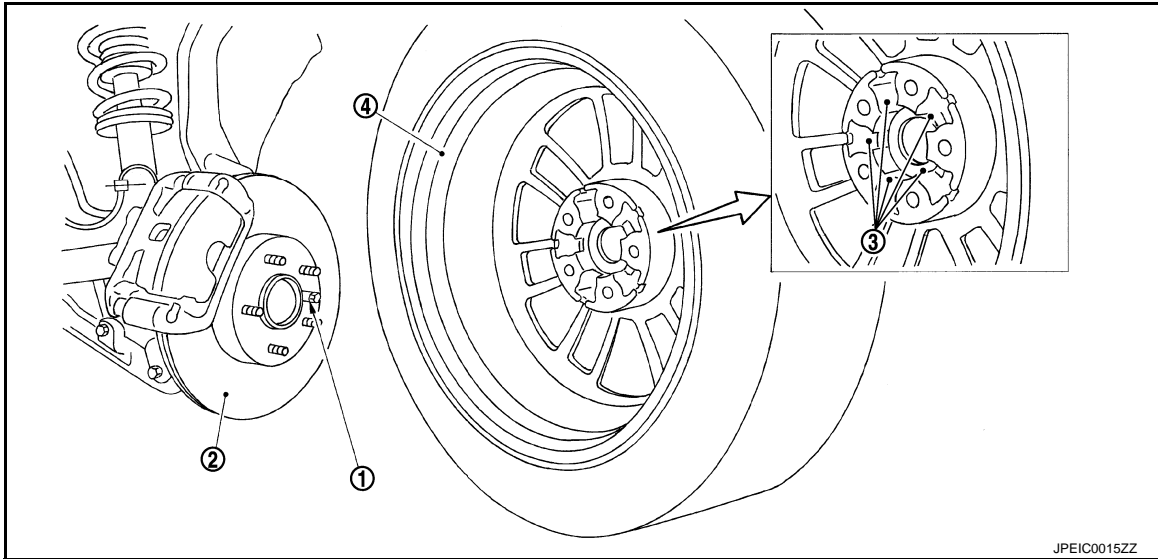

### T-TYPE SPARE TIRE WHEEL

- Regarding spare tire (for emergency) wheel, wrong assembly protection pin through hole (1) has been set in addition to regular bolt holes (2) in order to enable installation to front wheel.

#### NOTE:

Protection pin through hole of 18 inch spare wheel is non-through type.

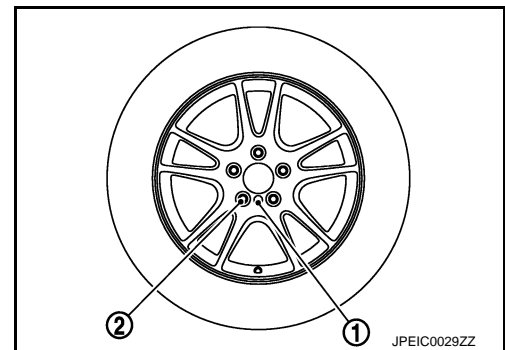

# ROAD WHEEL TIRE ASSEMBLY

< REMOVAL AND INSTALLATION >

## REMOVAL AND INSTALLATION

### ROAD WHEEL TIRE ASSEMBLY

Exploded View

INFOID:000000006206667

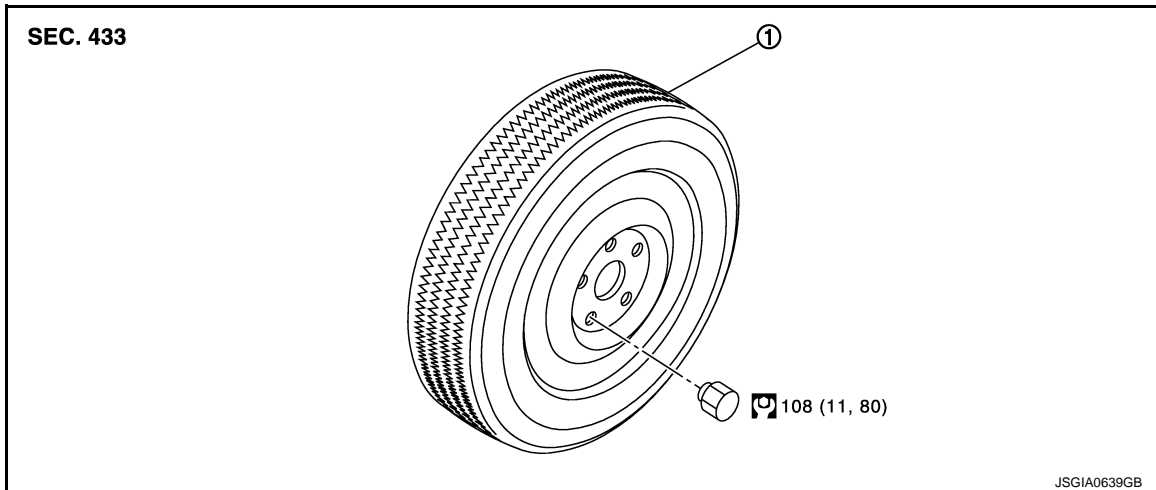

1. Tire assembly

Refer to [GI-4, "Components"](#) for symbols in the figure.

### Removal and Installation

INFOID:000000006206668

#### REMOVAL

1. Remove wheel nuts.
2. Remove tire assembly.

#### INSTALLATION

Note the following, install in the reverse order of removal.

- When replacing or rotating wheels, perform the ID registration. Refer to [WT-22, "Work Procedure"](#).

### Inspection

INFOID:000000006206669

#### ALUMINUM WHEEL

1. Check tires for wear and improper inflation.
2. Check wheels for deformation, cracks and other damage. If deformed, remove wheel and check wheel runout.
  - a. Remove tire from aluminum wheel and mount on a tire balance machine.
  - b. Set dial indicator as shown in the figure.
  - c. If the lateral deflection (A) or vertical deflection (B) for radial runout value exceeds the limit, replace aluminum wheel.

#### Limit

**A:** Refer to [WT-52, "Road Wheel"](#).

**B:** Refer to [WT-52, "Road Wheel"](#).

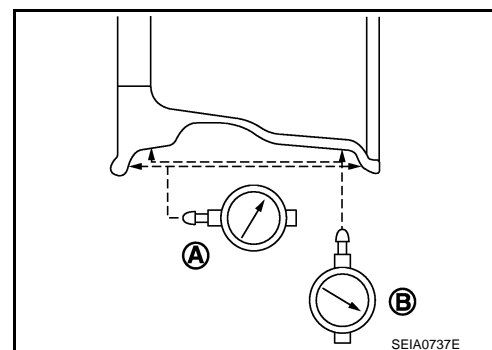

#### STEEL WHEEL

1. Check tires for were and improper inflation.

## ROAD WHEEL TIRE ASSEMBLY

### < REMOVAL AND INSTALLATION >

2. Check wheels for deformation, clacks and other damage. If deformed, remove wheel and check wheel runout.
  - a. Remove tire from steel wheel and mount wheel on a tire balance machine.
  - b. Set two dial indicators as shown in the illustration.
  - c. Set each dial indicator to "0".
  - d. Rotate wheel and check dial indicators at several points around the circumference of the wheel.
  - e. Calculate runout at each point as shown below.

**Lateral runout limit (A):**  $(1+2)/2$

**Radial runout limit (B):**  $(3+4)/2$

- f. Select maximum positive runout value and the maximum negative value. Add the two values to determine total runout.

**CAUTION:**

**In case a positive or negative value is not available, use the maximum value (negative or positive) for total runout.**

**Limit**

**A:** Refer to [WT-52, "Road Wheel"](#).

**B:** Refer to [WT-52, "Road Wheel"](#).

- g. If the total runout value exceeds limit, replace steel wheel.

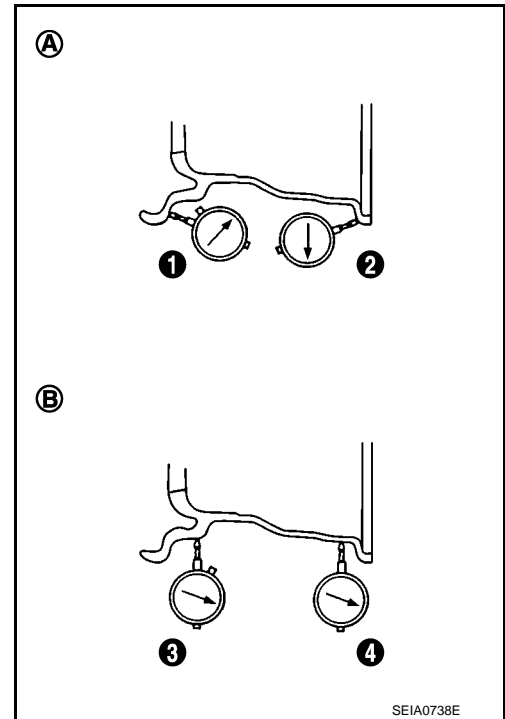



# TRANSMITTER

< REMOVAL AND INSTALLATION >

## TRANSMITTER

### Exploded View

INFOID:000000006206670

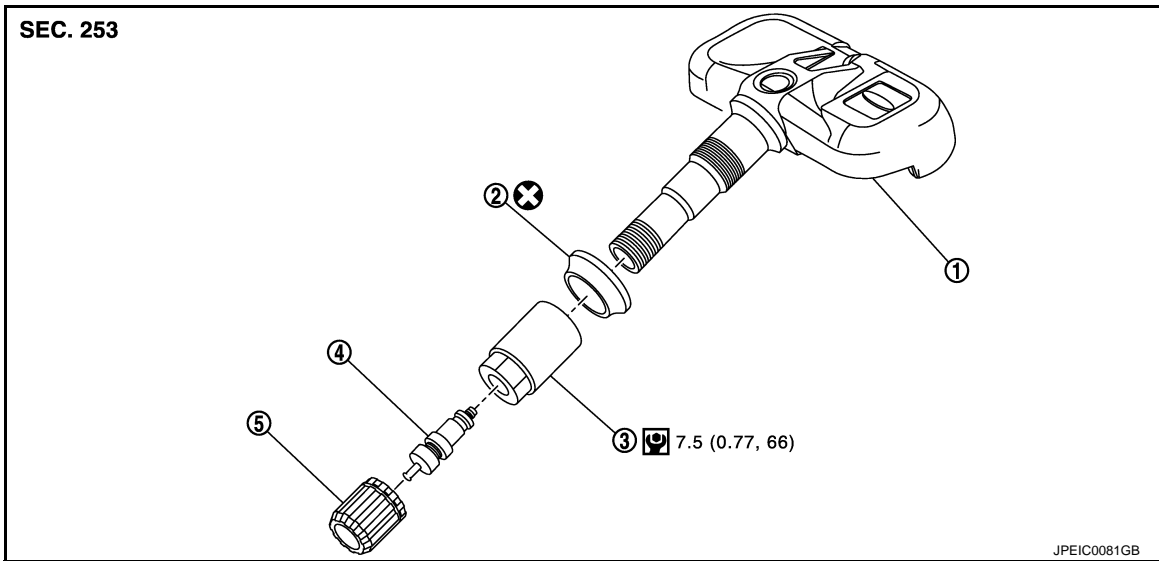

- |                |                 |              |
|----------------|-----------------|--------------|
| 1. Transmitter | 2. Grommet seal | 3. Valve nut |
| 4. Valve core  | 5. Cap          |              |

Refer to [GI-4, "Components"](#) for symbols in figure.

### Removal and Installation

INFOID:000000006206671

#### REMOVAL

1. Deflate tire. Unscrew transmitter retaining nut and allow transmitter to fall into tire.
2. Gently bounce tire so that transmitter falls to bottom of tire. Place on tire changing machine and break both tire beads ensuring that the transmitter remains at the bottom of the tire.

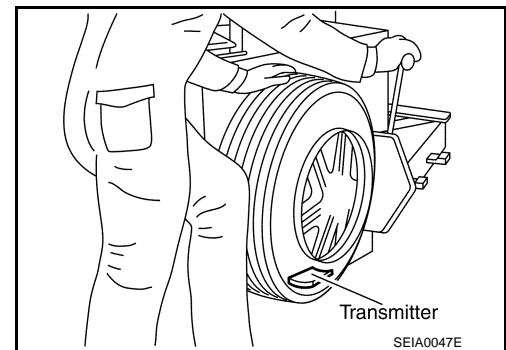

3. Turn tire so that valve hole is at bottom and bounce so that transmitter (1) is near valve hole. Carefully lift tire onto turntable and position valve hole (and transmitter) 270 degree from mounting/dismounting head (2).
4. Lubricate tire well and remove first side of the tire. Reach inside the tire and remove the transmitter.

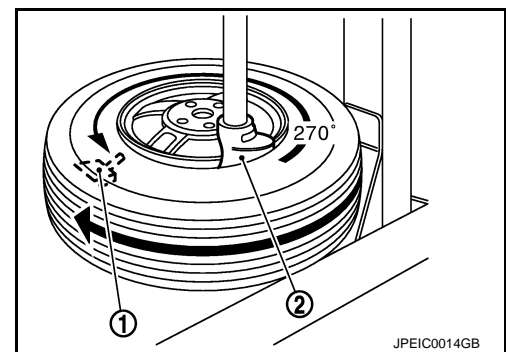

#### INSTALLATION

A  
B  
C  
D  
WT  
F  
G  
H  
I  
J  
K  
L  
M  
N  
O  
P

# TRANSMITTER

## < REMOVAL AND INSTALLATION >

1. Put first side of tire onto rim.

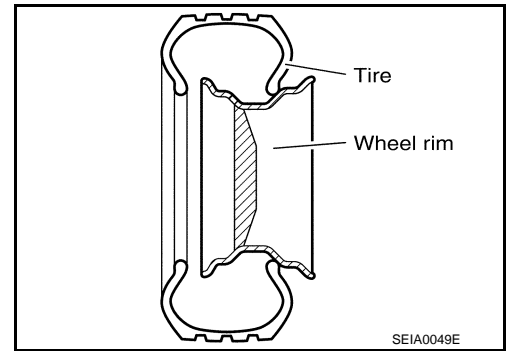

2. Mount transmitter on rim and tighten nut.

**CAUTION:**

**Speed for tightening nut should be less than 10 rpm.**

3. Place wheel on turntable of tire machine. Ensure that transmitter (1) is 270 degree from mounting head (2) when second side of tire is fitted.

**NOTE:**

Do not touch transmitter at mounting head.

4. Lubricate tire well and fit second side of tire as normal. Ensure that tire does not rotate relative to rim.
5. Inflate tire and fit to appropriate wheel position.
6. Perform the transmitter wake-up after replacing transmitter. Refer to [WT-21, "Work Procedure"](#).

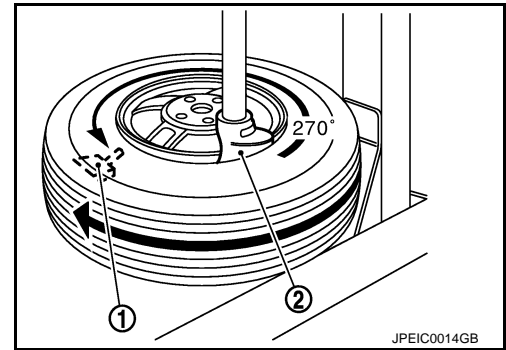

# TIRE PRESSURE RECEIVER

< REMOVAL AND INSTALLATION >

## TIRE PRESSURE RECEIVER

### Exploded View

INFOID:000000006206672

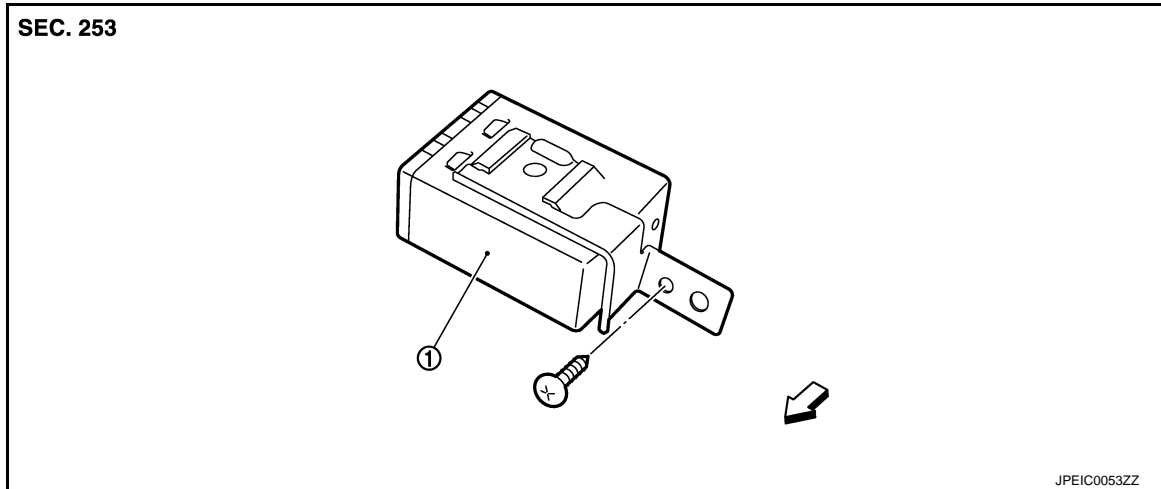

1. Tire pressure receiver

←: Vehicle front

### Removal and Installation

INFOID:000000006206673

#### REMOVAL

1. Remove the instrument lower cover. Refer to [IP-12. "A/T MODELS : Exploded View"](#) (A/T) or [IP-23. "M/T MODELS : Exploded View"](#) (M/T).
2. Remove the glove box assembly.
3. Remove the instrument lower panel RH.
4. Disconnect tire pressure receiver harness connector.
5. Remove Tire pressure receiver mounting screw.
6. Remove tire pressure receiver.

#### INSTALLATION

Install is the reverse order of removal.

## SERVICE DATA AND SPECIFICATIONS (SDS)

< SERVICE DATA AND SPECIFICATIONS (SDS)

# SERVICE DATA AND SPECIFICATIONS (SDS)

## SERVICE DATA AND SPECIFICATIONS (SDS)

### Road Wheel

INFOID:000000006206674

#### ALUMINUM WHEEL (CONVENTIONAL)

Item		Limit
Radial runout	Lateral deflection	Less than 0.3 mm (0.012 in)
	Vertical deflection	
Allowable unbalance	Dynamic (At flange)	Less than 5 g (0.17 oz) (one side)
	Static (At flange)	Less than 10 g (0.35 oz)

#### STEEL WHEEL (FOR EMERGENCY USE)

Item		Limit
Radial runout	Lateral deflection	Less than 1.5 mm (0.059 in)
	Vertical deflection	
Allowable unbalance	Dynamic (At flange)	Less than 5 g (0.17 oz) (one side)
	Static (At flange)	Less than 10 g (0.35 oz)

### Tire Air Pressure

INFOID:000000006206675

Unit: kPa (kg/cm<sup>2</sup>, psi)

Tire size	Air pressure	
	Front	Rear
P225/55R17 95V	230 (2.3, 33)	230 (2.3, 33)
P225/50R18 94V	230 (2.3, 33)	230 (2.3, 33)
225/50R18 95W	230 (2.3, 33)	–
245/45R18 96W	–	230 (2.3, 33)
T145/80D17	420 (4.2, 60)	420 (4.2, 60)
T145/70R18		