

INSTALLATION PROCEDURE:

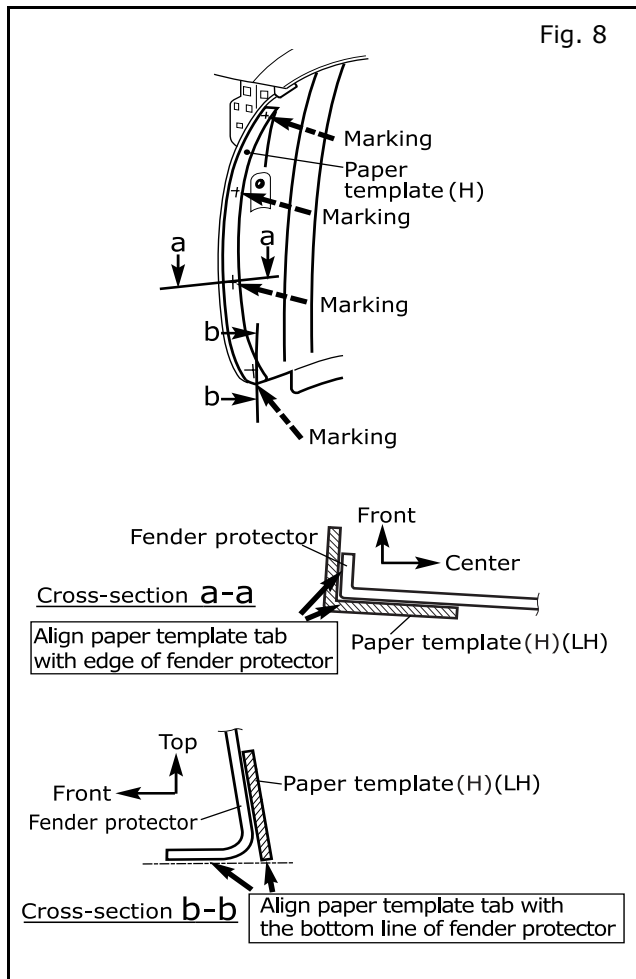
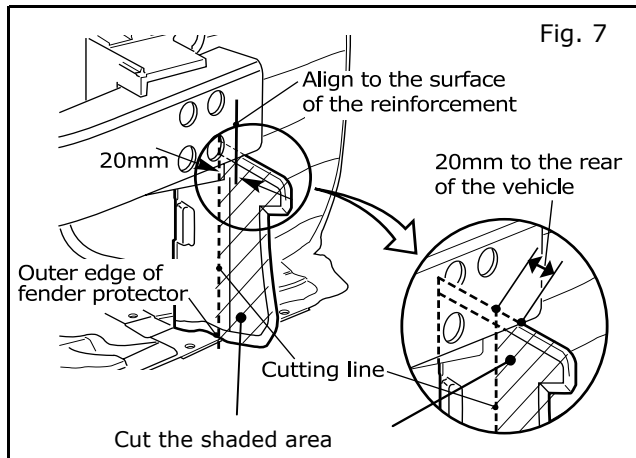

2) Vehicle part modification

- a) Detach the energy absorber from the reinforcement.
- b) Cut the front part of the air guide LH along the line by using scissors. See Fig. 7.
- c) Remove burrs remaining around the cut part.

NOTE:

This cut needs for both standard and sport grade.

- d) Turn tires.
- e) Temporarily attach the paper templates (H) by using masking tape (1 location on each side) in line with the shape of the fender protector.

NOTE:

Use the included sport vehicle template for both sport and standard vehicles. Do not use the standard vehicle template.

- f) Put a marking with a center punch at the cross mark part of the paper templates (4 locations on each side). See Fig. 8.
- g) Remove the paper templates.